



TEXAS A&M UNIVERSITY
Department of Biological
and Agricultural Engineering

GRADUATE HANDBOOK



TEXAS A&M UNIVERSITY
Engineering

Revised by the Department of Biological and Agricultural Engineering

Graduate Committee

Texas A&M University

College Station - TX-77843-2117

USA

Phone: (979)314-8220

baen.tamu.edu

January 2025

Table of Contents

| | |
|---|----|
| Welcome | 1 |
| Introduction | 2 |
| <i>Where are we located?</i> | 2 |
| Getting Started | 3 |
| <i>Admission Requirements</i> | 3 |
| <i>Admission Procedures</i> | 3 |
| <i>Whom to ask for Help?</i> | 5 |
| <i>Your Major Professor</i> | 5 |
| <i>Assignment of Graduate Office Space and Mailbox</i> | 5 |
| <i>Keys</i> | 6 |
| <i>Secretarial Support, Photo Copy Machines and Office Supplies</i> | 6 |
| <i>Use of Computers</i> | 6 |
| <i>Faculty/Staff/Students Lounge</i> | 7 |
| <i>Shop</i> | 7 |
| <i>Use of Departmental Vehicles</i> | 7 |
| <i>Purchase Orders</i> | 7 |
| <i>Travel Procedures</i> | 8 |
| <i>Employment Status</i> | 9 |
| <i>Parking on Campus</i> | 9 |
| <i>Use of State Property</i> | 9 |
| <i>Payment of Tuition Fees</i> | 9 |
| Requirements and Guidelines | 10 |
| <i>What to Do and When</i> | 11 |

| | |
|--|----|
| <i>Graduate Advisory Committee Selection</i> | 12 |
| <i>Committee Responsibilities</i> | 12 |
| <i>Graduate Advisory Committee Chair's Responsibilities:</i> | 13 |
| <i>Graduate Student's Responsibilities:</i> | 13 |
| Goals of Graduate Education in Biological & Agricultural Engineering at Texas A&M University | 15 |
| 1. <i>General</i> | 15 |
| 2. <i>At the Masters Level</i> | 15 |
| 3. <i>At the Doctoral Level</i> | 16 |
| Course Requirements for the Degree | 16 |
| 1. <i>Master of Science Degree in BAEN</i> | 16 |
| 2. <i>Master of Engineering Degree</i> | 20 |
| 3. <i>Master of Science Degree (AGSM) - Thesis Option</i> | 21 |
| 4. <i>Master of Science Degree (AGSM) - Non-Thesis Option</i> | 22 |
| 5. <i>Master of Agriculture Degree (AGSM)</i> | 22 |
| 6. <i>Doctor of Philosophy (Ph.D.) Degree</i> | 23 |
| 7. <i>Doctor of Engineering Degree</i> | 24 |
| 8. <i>Department Head Approval</i> | 24 |
| <i>Professional Internship</i> | 25 |
| <i>Registration Requirements Based Upon Level of Financial Support</i> | 26 |
| <i>Q-Drop Policy</i> | 26 |
| <i>Scholastic Deficiency</i> | 26 |
| <i>Annual PHD Student Progress Evaluation</i> | 27 |
| Examinations | 28 |
| <i>Final Examination</i> | 28 |
| <i>Preliminary Examinations for Ph.D. Students</i> | 28 |
| Theses, Dissertations and Records of Study | 30 |

| | |
|---|----|
| <i>1. Master of Science Thesis</i> | 30 |
| <i>2. Master of Engineering Report</i> | 30 |
| <i>3. Master of Agriculture Report</i> | 30 |
| <i>4. Doctor of Philosophy Dissertation</i> | 30 |
| Financial Assistance | 32 |
| <i>Teaching Assistantships</i> | 32 |
| <i>Research Assistantships</i> | 32 |
| <i>Extension Assistantships</i> | 32 |
| <i>Responsibilities</i> | 32 |
| <i>Graduate Scholarships</i> | 33 |
| International Students | 34 |
| <i>Things to Do Before Arriving on Campus</i> | 34 |
| <i>Other Important Items</i> | 35 |
| Appendix | 36 |
| <i>Appendix A – Degree Requirements: Quick Reference</i> | 36 |
| <i>Appendix B – Internship Documentation Form</i> | 46 |
| <i>Appendix C – Annual PhD Student Progress Form</i> | 47 |
| <i>Appendix D – Manuscript Tracking Form</i> | 50 |
| <i>Appendix E – Deadlines for completion of Degree Requirements</i> | 51 |
| <i>Appendix F – BAEN Facilities and Resources</i> | 52 |
| <i>Appendix G – Orientation Guide for New Graduate Studets</i> | 56 |

Welcome

Welcome to the Biological and Agricultural Engineering Department at Texas A&M University! Our department has a long and distinguished history of providing research and educational programs related to the engineering needs of the food and agricultural sciences. We have been consistently rated as one of the premier departments in the United States. Our faculty is well respected and active in various interdisciplinary professional societies, with several faculty members providing leadership in these societies. The Biological and Agricultural Engineering Department places a high priority on graduate education and offers a wide array of research topics. The research programs combine leadership in traditional areas of biological and agricultural engineering with aggressive development of programs in emerging technologies, including environmental and natural resources engineering, food and bioprocess engineering, systems analysis, machine and energy systems, and feed, food, and fiber processing. These programs are also conducted in several Research and Extension Centers located throughout the state.

Our graduate students come from many states and many countries around the world. You are encouraged to communicate with your fellow graduate students in order to benefit from their experience. Graduate students are a vital component of our department. As a graduate student you will gain experience in both the classroom and laboratory, increase the department's research capability, and, most importantly, bring new dimensions to its work. The real strength of our graduate program is the close interaction between graduate student and faculty member. Our faculty is extremely dedicated to the student's professional development and lifetime friendships have been built that span social and national boundaries. We are glad you are joining our team.

Please note that this handbook provides a guide for a student's graduate career in the BAEN department. However, it should not be considered a comprehensive representation of all the rules, policies and procedures that govern graduate studies at Texas A&M University.

Department of Biological and Agricultural Engineering
201 Scoates Hall
Texas A&M University
College Station, Texas 77843-2117
Phone: (979) 845-3931; Fax: (979) 862-3442
baen.tamu.edu

Introduction

This handbook provides information about our graduate programs to new and continuing graduate students in the department. It covers the academic policies concerning the many facets of graduate studies, including degree programs, examinations, and financial assistance. This handbook is not all-inclusive and students must refer to the Texas A&M University Graduate Catalog available on-line at catalog.tamu.edu and the website of the Graduate and Professional School at <https://grad.tamu.edu/#>. *The Graduate and Professional will be referred to as GPS in this document.*

Students should meet with their major professor (also referenced as the Graduate Committee Chair), the Director of Graduate Programs, and the graduate advisor/coordinator. All have experience and information to share and are able to help if students have any questions about their courses or specific problems not covered by this handbook.

Where are we located?

The BAEN Department is located in Scoates Hall. See the Campus map above or get the directions at aggiemap.tamu.edu

You can contact us at:

By Mail:

Biological & Agricultural Engineering Department

Texas A&M University

2117 TAMU

College Station, TX 77843-2117

By Phone: (979) 845-3931

Website: baen.tamu.edu/

Getting Started

This section describes some general departmental policies and procedures to help students use the facilities and proceed with their degree program.

Admission Requirements

Admission is primarily the responsibility of the department. The BAEN Department requires a 3.0/4.0 GPR or equivalent (on the last 60 hours of B.S. when applying for M.S.), 3.00 GPR (on previous degree when applying for Ph.D.) for admission. International students are required to fulfill an English proficiency requirement which is most commonly met with a minimum score of 146 on the GRE verbal test or a minimum TOEFL score of 80-iBT, 213 computer-based, or 550 paper-based. For details on requirements see <http://admissions.tamu.edu/international/graduate>. If these minimum scores are not met, the international student will not be granted admission to Texas A&M University. The department will not be able to review and consider an application until all required application documents have been received.

The Department of Biological and Agricultural Engineering requires students pursuing an engineering degree program to have a degree from an ABET-accredited engineering program or demonstrate that courses taken in previous academic preparation are equivalent to a BS in engineering. A student pursuing an agriculture degree must have a BS or equivalent in a recognized program.

Admission Procedures

Students must complete all required admission forms, which include a statement of purpose and letters of reference. Graduate admissions information is available at the Texas A&M University Office of Admissions website, <http://admissions.tamu.edu/graduate/apply>. Please keep in mind that all admission applications must be submitted via EngineeringCAS. Visit <https://baen.tamu.edu/academics/graduates/graduate-admissions/> for more details.

Admission applications to a degree program are evaluated by the BAEN Graduate Program Committee appointed by the Department Head. The chair of the Graduate Program Committee serves as the Director of Graduate Programs and is appointed by the Department Head. The committee uses a student information database (compiled by EngineeringCAS) to evaluate new applicants. Information found in the database includes: (1) GRE scores, (2) TOEFL scores, (3) Area of interest, (4) GPA, (5) Statement of Purpose, (6) Previous degrees and schools, (7) Starting semester, (8) Level of study applying for (degree sought), (9) Official Admission Records (OAR), (10) Application, (11) Recommendations, (12) Resume, (13) Major Professor, and (14) Academic Transcripts.

Introduction

The committee members evaluate student applications using the information in the above database and approve or deny the admission (by voting). Based on the outcome of the vote, the Director of Graduate Programs will sign acceptance or denial decisions electronically (via EngineeringCAS). The admissions office will then send out acceptance and denial letters to applicants. The department may also issue an admissions letter that contains specific information and conditions pertinent to the admissions process.

A student will not be admitted for graduate study without a faculty member having agreed to serve as his/her major professor. Applications with GPA/GPR < 3.0 that do not have a major professor identified will be automatically denied.

In limited instances, the committee may decide to admit students conditionally. In such instances the student will have to take appropriate action(s) to remove the *conditional* status as per stipulations imposed during the admissions process.

Removal of Conditional Admit status would be done as follows:

- **Conditional Admission with coursework levelling requirement(s):** The student will be admitted to the graduate degree program once all the levelling coursework has been completed with a grade of B or better.
- **Conditional Admission without GRE scores:** The BAEN Department requires GRE scores for final admissions decisions. In limited instances, as determined by the Department Head or the Director of Graduate Programs, the department may allow processing of an application pending GRE scores (for conditional admission). The student should present GRE scores to the BAEN Graduate Program committee who will decide on the final admission status.
- **Conditional Admission based on low entrance Grade Point Average/Ratio:** The student should achieve a cumulative GPR of 3.0 or better based on the courses he/she takes during the first semester. The student will have to register for a minimum of six credit hours that carry grades (i.e., excluding courses that carry S/U or I grades).
- **Any other conditional admission clause imposed by the Graduate Committee or the Director of Graduate Programs:** Evidence should be submitted to the Director of Graduate Programs (who will decide to put the file to the Graduate Committee for voting or make an admissions decision himself/herself based on the nature of the requirement(s)).

If a student does not fulfill any of the requirements stipulated when admitted conditionally, he/she will be placed on academic probation (see section on Scholastic Deficiency).

Whom to ask for Help?

In most cases, your major professor, the graduate advisor/coordinator or Director of Graduate Programs will be able to help. A list of all staff members who can assist you is provided in BAEN webpage under personnel.

Your Major Professor

This is the faculty member who, during the acceptance process, committed to serve as the chair of your graduate advisory committee. After arrival, students should meet with their major professor and can consult with other faculty members to become acquainted with their research areas. A student may request reassignment if it seems appropriate to all parties, usually no later than the first semester upon arrival.

Under no circumstances will a graduate student be allowed to remain in the BAEN Department graduate program if s(he) does not have a graduate advisor (major professor).

Should a student select an off-campus professor to be his/her Graduate Committee Chair/Major Professor, the student and professor must identify an on-campus Co-Chair by the time of arrival at the College Station campus for the entry semester.

Assignment of Graduate Office Space and Mailbox

Graduate students will receive office space, desk, and key assignments based on space availability. For inquiries, please visit the main departmental office in Room 201/202 Scoates Hall. Students are responsible for keeping their area clean. Any special needs for office and desk space should be initiated by the student's major professor. Graduate students are assigned office space either at Scoates Hall (SCTS) or at the West Campus complex.

All graduate students will be assigned a mailbox (Scoates 203B). The address for receiving mail is:

**Texas A&M University
Biological & Agricultural Engineering Department
Scoates Hall
2117 TAMU
College Station, TX 77843-2117**

Keys

Office, building, lab, and desk keys can be obtained in the department main office, Room 201 Scoates Hall. Your major professor will determine which keys you will be provided and will need to sign the key request form before keys can be issued.

Photo Copy Machines and Office Supplies

Office supplies are available for students performing work for the department. Students should make a request through their major professor. The staff is not permitted to do typing of a personal nature for students. This includes course work, theses, dissertations, and degree plans. Students must also have an access number to charge any photocopies made on the copy machines. This code is obtained through their major professor or faculty with whom they are currently working.

Use of Computers

The department maintains computers and facilities for Biological and Agricultural Engineering faculty, staff, and students. There are computer rooms, located in Rooms 213 and 214 of Scoates Hall and Room 118 in Hobgood (West Campus Complex). Access to the rooms is with an ID Card only. The department utilizes e-mail to distribute information and to communicate regularly. Students are responsible for the actions of anyone they let in to use the facilities after hours and should always be sure the door is locked after normal operating hours.

Note: Computer access is not automatic and comes with responsibility. The penalties are loss of computer privileges and any legal consequences that may result from violating the policies.

Faculty/Staff/Students Lounge

Students are welcome to use the facilities in Rooms 230 – Graduate Lounge. This lounge contains a microwave and refrigerator for graduate student use. There is a Keurig machine in SCTS 305A if you choose to bring coffee pods for your personal use. Everyone is responsible for cleaning up after himself or herself in the area.

Shop

Excellent shop facilities are available at our West Campus location for constructing research apparatus. Graduate students must obtain the permission of the shop coordinator to use the shop. Students must demonstrate to the shop coordinator their ability to safely use any of the shop equipment before permission is granted.

The shop personnel can assist in constructing research apparatus. Plans (including detailed drawings) and a work order should be submitted to the shop coordinator. The shop work order must be approved by the student's work supervisor or major professor prior to submittal. A detailed description of shop procedures and safety guidelines is available from the shop coordinator.

Use of Departmental Vehicles

Departmental vehicles may be used by students who are employed by the department and who are working on departmental projects. Proof of a current U.S. driver's license is required to use departmental vehicles. Drivers' licenses are available through the Texas Department of Public Safety. Approval of the major professor or work supervisor, as well as an account number to which the expenses may be charged, are required prior to vehicle use. You will need to check with the main office (SCTS 201) regarding training that might be required to use a departmental vehicle.

Purchasing Procedures

You will not need to use personal funds for research or teaching purchases. The student's supervisor should provide an account number and project number to which the purchase should be charged. Purchases under \$25,000 may be placed in AggieBuy, by credit card or purchase order. Check with your professor to see if they have a purchasing credit card you can use. Purchase orders are like checks written against the funds in an account. Please go to the quick tips for purchasing to view the departmental purchasing procedures and forms on the BAEN Unit Business Services website for additional information -

<https://agnettamu0.sharepoint.com/sites/BusinessServices/SitePages/Biological-and-Agricultural-Engineering-Business-Unit.aspx> All receipts/invoices related to purchases need to be sent to the Business office baen-business@exchange.tamu.edu.

If you have any questions, please contact the BAEN Business Office baen-business@exchange.tamu.edu

Travel Procedures

If you will be traveling with the Biological and Agricultural Engineering Department, please use the following procedures as a guide.

1. If you travel on official business you will need to first complete the following:

Introduction

- a. Travel Authorization Request. This is for all business travel, whether you will be requesting a reimbursement or not, and must be filled out in Concur (travel management software) prior to taking the trip.
 - b. Get the account name and project numbers from your advisor if being reimbursed for any travel expenses. You must have approval from your advisor prior to traveling.
 - c. Please view the departmental travel procedures under the quick tips on our BAEN Unit Business Services website -
<https://agnettamu0.sharepoint.com/sites/BusinessServices/SitePages/Biological-and-Agricultural-Engineering-Business-Unit.aspx>
2. Graduate students who are employees can apply for an individual travel agency credit card. You cannot use your own charge card (VISA, MasterCard, or American Express) to purchase airline tickets if using a state account; if you do, you will not be reimbursed for your airline ticket. Please email the BAEN Business Office baen-business@exchange.tamu.edu to apply for a travel agency credit card.
 3. Conference registration fees can be paid in advance using your travel agency credit card or purchasing credit card. Please keep your registration confirmation or get a receipt at the conference, you will need to submit this with your travel voucher or to the BAEN business office baen-business@exchange.tamu.edu if you use a purchasing credit card. If you pay for the conference registration using your own credit card you will get reimbursed after your trip is complete.
 4. The University has numerous lodging accommodations that have been contracted by the State of Texas. Reservations can be made through Concur. If you pay for the expenses using your own credit card you will get reimbursed after your trip is complete. Please make sure you keep your hotel receipt(s) and do not mark on them in any way. If two or more travelers will be sharing lodging the room receipt must be separate and each traveler must have his/her own receipt. If you are traveling in the State of Texas, make sure the receipt shows the State tax exemption.
 5. The University has contracts with Enterprise & Hertz for rental car use. Reservations can be made through Concur. If you pay for the expenses using your own credit card, then you will get reimbursed after your trip is complete. Please keep your receipt and make sure that you take a copy of the Exemption Form with you when you pick up the vehicle.
 6. After travel has been completed it will be your responsibility to submit your expense report within 30 days of the trip in Concur. Please contact the BAEN Business Office baen-business@exchange.tamu.edu if you need assistance.

If you have any questions, please contact the BAEN Business Office baen-business@exchange.tamu.edu. Do not wait until after the travel is complete.

Employment Status

You will be sent to the departmental business offices to fill out the paperwork associated with your employment status. If a student's employment status changes (e.g. from Research Assistant (RA) to Teaching Assistant (TA)), the department's Business Manager should be notified. Failure to do so may result in a late paycheck.

Parking on Campus

As a student, you can purchase a parking permit in a student-designated lot at the time you register for classes.

The university shuttle is also available both for on and off campus transportation of students. Transit routes for both on and off-campus can be found at <http://transport.tamu.edu/BusRoutes/>, or at 979-862-7275 (parking) or 979-847-7433 (bus operations).

Use of State Property

It is against State Law in Texas to use any state-owned property for personal use.

Payment of Tuition Fees

Information including cost per scheduled hour, tuition and fee calculator, payment due dates and more can be found at the Student Business Services website at:

<https://sbs.tamu.edu/index.html>

Requirements and Guidelines

All graduate students should review the following publications:

1. The Graduate and Professional School:
<https://grad.tamu.edu/#>
2. The Texas A&M Graduate Catalog:
<http://catalog.tamu.edu>
3. The University's Student Rules Handbook:
<http://student-rules.tamu.edu>
4. The Texas A&M University Thesis Office:
Resources for Degree Completion:

All students must follow the guidelines and meet the requirements as given in these documents. The Department has additional requirements that all students must fulfill to earn a graduate degree in Biological and Agricultural Engineering at Texas A&M University. Requirements for the various degrees in Biological & Agricultural Engineering, including both University and Departmental requirements, are listed next/below. Details on the University requirements can be found in the documents listed previously/above. Note that some of the **Departmental deadlines are earlier than the University deadlines.**

What to Do and When

Masters Students:

| When | What |
|-------------------------------------|---|
| Before first semester registration | Meet with major professor to plan course of study for first semester |
| Before second semester registration | Establish Advisory Committee |
| Early in second semester | Submit Degree Plan on-line at https://ogsdpss.tamu.edu/ |
| Prior to initiating thesis research | Develop draft of proposal in conjunction with major professor and graduate committee members (only for M.S. students) |
| | Submit final research proposal to GPS |
| During final semester | Apply for degree |
| | Pay diploma fee |
| | Schedule final oral examination |
| | Submit thesis on-line |
| | Apply for graduation (http://graduation.tamu.edu) |

Doctoral Students:

| When | What |
|--|--|
| Before first semester registration | Meet with major professor to plan course of study for first semester |
| Before third semester registration | Establish Advisory Committee |
| Early in fourth semester | Submit Degree Plan on-line at https://ogsdpss.tamu.edu/ . The department of Biological and Agricultural Engineering requires a 90 day wait period between having a degree plan on file and completing the preliminary examination. |
| No later than one semester after all course work is completed, and no earlier than date at which student is within 6 credit hours of completing formal course work | Schedule and take preliminary examinations (written and oral). A dissertation proposal should be submitted along with the preliminary examination. The department of Biological and Agricultural Engineering requires a 14 week waiting period between completion of the preliminary examination and taking the final examination. |
| Prior to initiating dissertation research | Develop draft of research proposal in conjunction with major professor and graduate committee members |
| | Submit final research proposal to GPS |
| During final semester | Apply for degree |
| | Pay diploma fee |
| | Schedule and take final oral examination |
| | Submit dissertation on-line |
| | Apply for graduation (http://graduation.tamu.edu) |

This information is subject to change; please visit following website for more up-to-date information:

Student requests regarding degree plan, final exam, etc are to be submitted through ARCS in howdy.tamu.edu

Graduate Committee Selection

Students will select the other committee members in consultation with their committee chair. All Biological & Agricultural Engineering Department faculty members who hold a Ph.D. degree (this includes tenured/tenure-track/and Agency appointments) are eligible to serve as chair, co-chair, and member of BAEN graduate student committees.

When a BAEN off-campus faculty member serves as chair, an on-campus BAEN faculty member will be appointed as co-chair. This practice is intended to best serve the interests of the students.

Faculty and professional staff employed by other institutions and organizations can serve as graduate committee special appointments.

Students should contact each prospective committee member, have an interview with him/her and ask him/her to be a member of their committee. The student should review the proposed degree plan with the prospective member. The committee member's electronic approval of the degree plan indicates his/her willingness to participate in guiding and directing the student's entire academic program. Individual committee members may be replaced by petition for valid reasons. Both degree plans and petitions are submitted on-line at the GPS website.

| Degree | Committee Members | Affiliation |
|---------------|--------------------------|---|
| Masters | 3 | 2 from BAEN (including Chair), 1 from outside BAEN |
| Doctoral | Minimum of 4 | 2 from BAEN (including Chair), at least 1 from outside BAEN |

Committee Responsibilities

The student's advisory committee has responsibility for assessing the appropriateness of the proposed degree program, the research proposal, the thesis and the final examination. In addition, the committee is expected to provide periodic advice and assistance to the graduate student. At the doctoral level, the committee also has the responsibility for the Ph.D. preliminary examination and the qualifying examination for the Doctor of Engineering.

Graduate Committee Chair's Responsibilities:

1. Responsibility for the guidance, training, evaluation, supervision and general arrangements for the graduate student.
2. Conduct regularly scheduled conferences with each student at least every semester. Weekly conferences are normal as the graduate student becomes active in his/her research or project.
3. Acquaint the student with departmental policies and provide personal counseling.
4. Arrange resources for the graduate student's research and see that the student has a valid safety checklist for that area.
5. Check and approve all necessary graduate forms and requests for materials, travel and service.
6. Assist the student in preparing a degree plan and research proposal.
7. Evaluate the graduate student's performance on a regular basis and convey the results of the evaluation to the student.
8. After the student has arranged an appropriate schedule, submit the announcement of the final examination to the GPS and graduate committee members.
9. After the student has arranged an appropriate schedule, submit the schedule for the preliminary examination for Ph.D. candidates and the qualifying examination for Doctor of Engineering candidates to the GPS and graduate committee members.
10. Direct the administration of the preliminary examination, qualifying examination and final examination and report the results of the examinations to GPS.
11. Make an initial approval of the record of study, thesis, or dissertation and decide when it is satisfactory for graduate committee action.

Graduate Student's Responsibilities:

1. Register for the appropriate courses and the proper number of credit hours for each semester and summer term (See Course Requirements).
2. Complete all courses on the degree plan satisfactorily (maintain an overall grade point ratio of 3.0 or higher; 3.25 for Doctor of Engineering students) (See Scholastic Deficiency). Graduate students are expected to make a B or better in all courses.
3. Develop the objectives for his/her program and provide the initiative to accomplish these objectives.
4. Select members of the graduate committee.

Requirements and Guidelines

5. Prepare and submit the degree plan to GPS.
6. Develop a research proposal in consultation with the graduate committee chair and the graduate committee and submit the proposal to GPS.
7. Prepare and submit a high-quality record of study, thesis or dissertation.
8. Present a departmental seminar on thesis, dissertation, or internship report.
9. Schedule with committee members the final, preliminary and qualifying examinations. Provide a schedule to the graduate committee chair so that he/she can send an announcement of the examination to GPS.
10. Develop manuscript(s) (minimum 1 for M.S.; 2 for Ph.D.) for publication in peer-reviewed journals to communicate research results to the pertinent literature.

Goals of Graduate Education in Biological & Agricultural Engineering at Texas A&M University

1. General

- To explore the use of science and technology in problem solving for the benefit of society
- To further career opportunities
- To participate in the process of continuous education
- To develop and enhance professionalism
- To develop leadership and management skill
- To develop communication skills, written and oral
- To develop self-discipline and self-educating capabilities

2. At the Masters Level

- To develop the capability to plan, conduct, and document research in accordance with accepted scientific methodology
- To learn to function as a member of a team or organization
- To prepare for the pursuit of further specialization or advanced degree
- To communicating research results orally and in the pertinent literature

3. At the Doctoral Level

- To develop the capability to conduct independent research by writing proposals, planning research, conducting research, administering projects, managing support personnel, and communicating research results orally and in the pertinent literature
- To develop teaching skills through formal study of pedagogical methods, supervised classroom teaching experience, and fostering a positive attitude towards teaching
- To develop a high level of expertise in a particular subject area
- To develop new knowledge

COURSE REQUIREMENTS FOR THE DEGREE

Courses to be included on a student's degree plan are selected as a joint effort between the student and his/her graduate committee. The student's graduate committee and the BAEN department head must approve all degree plans.

All graduate students receiving assistantships are required to register as full time students —9 credit hours during the fall and spring semesters; 6 in summer (3 in each summer session or 6 for the 10-week session). Those on financial assistance through TAMU Scholarships and Financial aid and other sources (e.g. fellowships, sponsorships, etc) must check with relevant entities to obtain registration guidelines.

Students not receiving financial assistance who have completed all course work are required to be in **continuous registration** until all requirements for the degree have been completed by registering for a minimum of one credit hour for fall and spring semesters and the 10-week summer session.

International students must also comply with registration requirements according to their visa status.

1.1 Master of Science Degree in BAEN – Thesis Option

A. A minimum of 30 credit hours distributed as follows:

*Note: student entering Texas A&M University beginning Fall 2019 will be on a **30** credit hour degree program.*

1. A minimum of 24 course credit hours

2. A maximum of 6 research credit hours (BAEN 691)

note: students entering Texas A&M University beginning Fall 2019 are required to take no more than 6 hours of research credit

3. BAEN 681 (Graduate Seminar)

4. BAEN 690 (Theory of Research)

5. BAEN 683 (Peer-Review Process and Publication)

6. A minimum of 6 credits of formal course work at the 600 level Biological & Agricultural Engineering Courses (in addition to all 684, 685, 690, 683, and 691 credits)

7. A maximum of 6 BAEN 685 and 689 credits

A. Student must specify which class they are taking - not just 689 Special Topics

B. Must be formally offered course work, special problems or special studies

C. May exceed maximum 6 credits with departmental approval.

8. A maximum of 9 hours of advanced undergraduate course (300 or 400-level)

None of the BAEN required undergraduate courses can be used on a graduate degree plan (only the electives).

9. One 600 level mathematics course (MATH 601 or equivalent). Classes approved for BAEN are:

- a. MATH 601 - Methods of Applied Mathematics I (Linear Algebra)
- b. MATH 609 - Numerical Analysis
- c. MATH 611 - Introduction to Ordinary and Partial Differential Equations
- d. MATH 612 - Partial Differential Equations
- e. MATH 647 - Mathematical Modeling
- f. MATH 664 - Seminar in Applied Mathematics
- g. CHEN 604 - Chemical Engineering Process Analysis I
- h. ECEN 601 - Linear Network Analysis

10. One 600 level statistics or equivalent (minimum of 3 hrs). Class approved for BAEN are:

- a. STAT - any 600 level
- b. BAEN 661 - Experimental Methods in Biological and Agricultural Engineering

c. BAEN 662 - Statistical Methods in Biological and Agricultural Engineering

11. A maximum of 12 transfer credits

These requirements will be followed unless advisor can make strong logical arguments to the Department Head or Graduate Program Chair/Associate Head towards minor exceptions.

The graduate student's committee must be formed early in the student's program and the committee review and approve the degree plan as early as possible in the student's program. The degree plan must be signed by all members of the committee before the plan is reviewed by the Department Head. The degree plans should be submitted in the system at least two weeks before they are due, to allow enough time for them to be studied thoroughly.

B. A final oral examination over the written thesis.

1.2 Master of Science Degree in BAEN – Non-thesis Option

A. A minimum of 30 credit hours distributed as follows:

*Note: students entering Texas A&M University beginning Fall 2019 will be on a **30** credit hour degree program. BAEN non-thesis student committee comprises of only one member who serves as the major professor/committee chair. The course requirements are kept flexible to accommodate student's career goals, and the course program should be developed by the student in consultation with the major professor while complying with the following requirements:*

1. BAEN 681 (Graduate Seminar)
2. A minimum of 6 credits of formal course work at the 600 level Biological & Agricultural Engineering Courses (in addition to all 684, 685, 690, 683, and 691 credits)
5. A maximum of 6 BAEN 685 and 689 credits

- A. Student must specify which class they are taking - not just 689 Special Topics
- B. Must be formally offered course work, special problems or special studies
- C. May exceed maximum 6 credits with departmental approval.

6. A maximum of 9 hours of advanced undergraduate course (300 or 400-level)

None of the BAEN required undergraduate courses can be used on a graduate degree plan (only the electives).

7. One 600 level mathematics course (MATH 601 or equivalent). Classes approved for BAEN are:

- a. MATH 601 - Methods of Applied Mathematics I (Linear Algebra)
- b. MATH 609 - Numerical Analysis
- c. MATH 611 - Introduction to Ordinary and Partial Differential Equations
- d. MATH 612 - Partial Differential Equations
- e. MATH 647 - Mathematical Modeling
- f. MATH 664 - Seminar in Applied Mathematics
- g. CHEN 604 - Chemical Engineering Process Analysis I
- h. ECEN 601 - Linear Network Analysis

8. One 600 level statistics or equivalent (minimum of 3 hrs). Class approved for BAEN are:

- a. STAT - any 600 level
- b. BAEN 661 - Experimental Methods in Biological and Agricultural Engineering
- c. BAEN 662 - Statistical Methods in Biological and Agricultural Engineering

9. A maximum of 12 transfer credits

B. The final examination is waived.

These requirements will be followed unless advisor can make strong logical arguments to the Department Head or Graduate Program Director/Associate Head towards minor exceptions.

The graduate student's committee must be formed early in the student's program and the committee review and approve the degree plan as early as possible in the student's program. The degree plan must be signed by all members of the committee before the plan is reviewed by the Department Head. The degree plans should be submitted in the system at least two weeks before they are due, to allow enough time for them to be studied thoroughly.

2. Master of Engineering Degree

A. A minimum of 30 credit hours to be distributed as follows:

1. A maximum of 6 credit hours of BAEN 684 (Professional Internship – see more information in the Professional Internship section). Three hours of BAEN 684 (internship) are a requirement for a Master of Engineering in Biological and Agricultural Engineering.
2. A maximum of 6 credit hours of BAEN 685 (Special Problems)
3. BAEN-681 (Graduate Seminar)
4. Any combination of 684 and 685, may not exceed 25% of the total hour requirement
5. One 600 level mathematics course (MATH 601 or equivalent) – See approved list under Master of Science Degree
6. A maximum of 9 hours of advanced undergraduate course (300 or 400-level)
7. A minimum of 6 credits of formal course work at the 600 level Biological & Agricultural Engr Courses (in addition to all 684 and 685, and 681 credits)
8. No credit hours of BAEN 691 (Research) may be used

B. A final oral examination over the written report is required.

None of the BAEN required undergraduate courses can be used on a graduate degree plan (only the electives).

3. Master of Science Degree (AGSM) - Thesis Option

Thesis-Option Degree Plan Requirement

A. A minimum of 32 credit hours distributed as follows:

1. A minimum of 24 course credit hours
2. A maximum of 8 research credit hours (BAEN 691)
3. BAEN 601-Advanced Agricultural Systems Analysis (3 hours)
4. BAEN 681-Seminar (1 hour)
5. BAEN 683-Peer Review Process and Publication (1 hour)
6. BAEN 690-Theory of Research (1 hour)
7. STAT 651 - Statistics in Research I (or other advisory committee approved equivalent 3 credit hour 600-level Statistics course; i.e. BAEN 661, 662)
8. Minimum of 6 credit hours of BAEN 6xx-level courses (in addition to 681, 683, 690, 691)
9. Maximum of 6 credit hours of BAEN 685 and 689 credits (specific 689 class must be indicated)
10. Maximum of 9 credit hours of advanced undergraduate 300-400 level courses

None of the AGSM required undergraduate courses can be used on a graduate degree plan (only the electives).

11. Maximum of 12 transfer credit hours
- B. A final oral examination over the written thesis.

4. Master of Science Degree (AGSM) - Non-Thesis Option

Non-Thesis Option Degree Plan Requirements

Minimum of 36 credit hours distributed as follows:

1. BAEN 60I - Advanced Agricultural Systems Analysis (3 hours)
2. BAEN 681 - Graduate Seminar (1 hour)
3. Minimum of 9 credit hours of BAEN 6xx-level courses (in addition to 681)
4. Maximum of 9 credit hours of BAEN 685 and 689
5. Maximum of 9 credit hours of advanced undergraduate 300-400 level courses

None of the AGSM required undergraduate courses can be used on a graduate degree plan (only the electives).

6. No credit hours of BAEN 691
7. Maximum of 12 transfer credit hours

5. Master of Agriculture Degree (AGSM)

A. A minimum of 36 credit hours to be distributed as follows:

1. A maximum of 8 credit hours of BAEN 684 (Professional Internship)
2. A maximum of 8 credit hours of BAEN 685 (Special Problems)
3. BAEN-681 (Graduate Seminar)
4. Any combination of 684, 685, 683, and 690 may not exceed 25% of the total hour requirement
5. A maximum of 18 credit hours on courses outside of the degree option
6. A maximum of 9 hours of advanced undergraduate course (300 or 400-level)
7. No credit hours of BAEN 691 (Research) may be used

B. A final oral examination over the written report is required

6. Doctor of Philosophy (Ph.D.) Degree

The Doctor of Philosophy degree is a research-oriented degree requiring a minimum of: 64 credit hours of approved courses and research beyond the Master of Science degree or 96-semester credit hours beyond the baccalaureate degree.

A. Credit hours in the degree plan should be distributed as follows:

1. A maximum of 40 research credit hours (60 for student enrolling into a PhD program directly from a BS)
2. A minimum of 24 course credit hours (minimum of 36 hours for a student enrolling into a PhD program directly from a BS)
 - BAEN 681 (Graduate Seminar)
 - BAEN 690 (Theory of Research)
 - BAEN 683 (Peer-Review Process and Publication)
3. A minimum of 6 credits of formal course work at the 600 level Biological & Agricultural Engineering Courses (in addition to all 684, 683, 685, 690 and 691 credits and in addition to any 600 level courses earned at the M.S. level in this department)
4. A maximum of 3 credits hours of BAEN 685
5. One 600 level mathematics course (see acceptable courses under MS degree)
6. One 600 level statistics course (STAT 601) or equivalent

Students who have already fulfilled above mathematics and statistics requirements with a grade B or better during a MS degree do not have to take additional mathematics and statistics courses unless as advised by the student advisory committee.

B. Successful completion of a preliminary examination, both written and oral, prepared and administered by the student's Advisory Committee

C. A defense of the Dissertation

D. A dissertation, approved by the student's Advisory Committee, based on the research conducted as part of the graduate program Students not holding an M.S. degree in engineering will be required to take additional collateral courses in the Biological & Agricultural Engineering curriculum at the 400 level or below as specified by the department.

Students who obtained their Master degree at the BAEN department will have to re-take BAEN-681 and BAEN-683 as a requirement for their PhD degree.

7. Doctor of Engineering Degree

<http://engineering.tamu.edu/media/42918/doemmanual.pdf>

Interested students are referred to the website above to learn of the specific requirements for admission and program completion.

A condensed version of degree requirements could be found in **Appendix A.**

A condensed version of degree requirements could be found in **Appendix A.**

8. Department Head Approval

The BAEN Department Head (DH) intends to follow the spirit of the requirements in the student manual, but will make exceptions to the requirements if good arguments are made to justify the changes. If the degree plan does not meet the requirement, then the student's major advisor should write and sign a memo to the DH to justify the variation(s). The graduate student's committee must be formed early in the student's program and the committee review and approve the degree plan as early as possible in the student's program. The degree plan must be signed by all members of the committee before the plan is reviewed by the Department Head. The degree plans should be sent to the DH two weeks before they are due, to allow enough time for them to be studied thoroughly.

A list of the steps and/or forms that the DH must approve are given below:

Note: this list is not comprehensive but gives a list of the most common items which need DH approval

- Degree plan
- Request and announcement of final examination
- Thesis/Dissertation Approval Form

Professional Internship

In those programs in which a professional internship is used, a student will spend an appropriate period of time under the supervision of a practicing professional in industry, business, an educational institution or a government agency. The objectives of the internship are two-fold:

1. to enable the student to demonstrate the ability to apply technical training and knowledge by making an identifiable contribution in an area of practical concern to the industry or organization in which the internship is served, and
2. to enable the student to function in a non-academic environment in a position in which he or she will become aware of the organizational approach to problems in addition to those traditional approaches with which the student is familiar.

Internship agreements should be negotiated between the appropriate organization or industry and the department. The organization of the internship, the internship supervisor and the nature of the internship will be determined by mutual consent of the student, the head of the student's major department, the chair of the student's advisory committee, the student's advisory committee and the supervising organization prior to the commencement of the internship period. The internship experience should be at a level commensurate with the particular degree objective.

The student should complete the Internship Documentation Form, obtain appropriate signatures and hand over the completed form to the BAEN Graduate Advising Office prior to beginning of the internship duties. A sample form could be found in the **Appendix B**. An updated form could be obtained by BAEN Graduate Advising Office.

It is the student's responsibility to find an internship that fits both his/her professional aspirations and degree requirements. One credit hour of BAEN 684 Professional Internship is estimated to be one month of full time employment (or as agreed upon by the student graduate advisory committee). Once completed, the student should provide a letter to the Student Advisory Committee with information on the location, duration and the nature of duties performed signed by an authorized official at which the internship took place.

Additionally, an internship report should be prepared by the student in accordance with guidelines established by the department, and/or the student's advisory committee. In general, the report should be submitted to the advisory committee. The internship report must be the original work of the student.

An internship, if utilized as part of a student's degree requirements, should be undertaken near the end of the student's educational program, after the student has had the opportunity to establish a solid theoretical base for the internship experience.

Registration Requirements Based Upon Level of Financial Support

| Level of Financial Support | Registration Requirements |
|---|--|
| ½ time employment (including all teaching, non-teaching, research, and Extension assistants, plus any 1/2time hourly wage students) | 9 credit hours for each full semester and 3 credit hours for each five-week summer term or 6 credit hours for the ten-week summer session. |

Q-Drop Policy

Texas A&M University allows courses to be dropped after the official Drop/Add deadline using Q-Drop procedures. A Q-Drop allows the student to drop a course during the semester without academic penalty. Q-drop requests are submitted electronically through howdy.tamu.edu for processing by the staff academic advisor. Students must keep in mind that dropping below full time enrollment can impact assistantships, fellowship, scholarships, international status, etc. Graduate students should be discouraged from Q-drops whenever possible.

Scholastic Deficiency

A student will be placed on scholastic probation for any of the below reasons:

- if the student's cumulative grade point average (GPA) for the courses on the approved degree plan is below 3.0 at the end of a semester
- if the student's cumulative grade point average for the term is below 3.0 at the end of the semester
- if the student fails to show acceptable proficiency in other degree requirements such as examinations, research, writing the thesis or dissertation, etc.

A communication will be received by the student stating that he/she has not met the requirements and that he/she has one semester to improve. If the student is on an assistantship, funding will be suspended.

The student has one semester to make up the total deficiency. If the student is successful, he/she will be taken off probation. An email/letter from the Director of Graduate Programs will be placed in student file that the conditional admit status has been removed.

If the student fails to meet the requirements, he or she may be subjected to one of the following actions initiated by a recommendation from the student's major professor: permitted to continue in the program on scholastic probation for one additional semester or suspended from the program. At the conclusion of the second semester under probation, if the student has not been able remedy the deficiencies he/she will be force dropped from classes and a hold will be placed preventing him/her from re-enrolling and the student will

be terminated from the program. At that time, a letter of dismissal will be issued and placed in the student's file. It should also be noted that scholastic deficiency may cause the student to be suspended from the university (See section 12.5 in Student Rules and Regulations).

Annual PhD Student Progress Evaluation

Doctoral students are required to complete the Annual PhD Student Progress Form each year in consultation with the student's major professor. Such an evaluation is done to ensure that both the student and the major professor are aware of the student's progress toward timely completion of the Ph.D. program while also allowing the student to plan the upcoming year and address any pertinent issues. Failure to complete the evaluation will result in an academic hold being placed on the students file which will prevent registration in future terms. A sample form can be found in Appendix C.

Examinations

Complete information can be found in the Texas A&M University Catalog.

Final Examination

All degree candidates must pass a final examination, and the request for the final exam will be initiated through ARCS in howdy.tamu.edu. Deadline dates are announced each semester by GPS. At the time of the final examination, the student must have an overall GPA of at least 3.0. Furthermore, there must be no unresolved grades of D, F or U for any course listed on the student's degree plan. An announcement of the final examination will be made by the student's graduate committee chair at least two weeks before the scheduled examination date. A student must have completed all course work on his/her degree program with the exception of any remaining 691 (Research) hours. The student must be registered at the time of the examination. M.S. and Ph.D. degree candidates must have approved research proposals on file with GPS before they can take the final examination.

The thesis, report, or dissertation shall be distributed to the student's graduate committee at least two weeks before the final examination. The final examination is a defense of the student's research. However, committee members are free to examine the student on any subject, such as all course work listed on the degree program. At the opinion of the student's graduate committee, the final examination may be written or oral or both. If a student fails the final examination, the student will be given the opportunity to repeat the examination before the end of the next semester (summer terms excluded). Final examinations must be administered on the campus of Texas A&M University at College Station.

The department of Biological and Agricultural Engineering requires a 14-week waiting period between completion of the preliminary examination and taking the final examination.

Preliminary Examinations for Ph.D. Students

The preliminary examination shall be given no later than the end of the first semester after completion of course work and no earlier than a date at which the student is within approximately 6 credit hours of completion of the formal course work on the degree plan. No student may be given the preliminary examination unless his/her official GPA is 3.0 or higher. The examination shall be both written and oral. The written part will cover each field of study included in the student's program of study. Each of the student's graduate committee members will be responsible for administering a written examination in the member's particular field. The BAEN department requires all departmental committee

members to give a written preliminary examination. Non-BAEN committee members may choose to waive participation in the written examination.

The student should meet with his/her committee members and arrange for mutually acceptable dates for both the written and oral exams. Normally each written exam requires one day and the oral examination is completed within three hours. Both the oral and written portions of the preliminary examinations must be administered on the campus of Texas A&M University at College Station. Both parts (written and oral) of the preliminary examination should be completed within a period of two weeks.

The student will initiate the request for the prelim exam through ARCS in howdy.tamu.edu and the graduate committee chair will submit the Report of the Preliminary Examination to GPS. After passing the preliminary examination, the student must complete all remaining requirements for the degree within four calendar years. Otherwise, the student will be required to repeat the preliminary examination. A student who fails the preliminary examination may be given one re-examination, but only after a period of six months has elapsed. A student must be registered in any semester that he/she takes the preliminary examination.

A dissertation proposal should be submitted along with the preliminary examination report.

The department of Biological and Agricultural Engineering requires a 90-day wait period between having a degree plan on file and completing the preliminary examination.

Theses, Dissertations and Records of Study

Complete information can be found in the Texas A&M University Thesis Manual.

1. Master of Science Thesis

A final draft of the thesis must be submitted to the graduate committee at least two weeks before the final examination. After the final examination, corrections shall be made to the thesis prior to submitting it to the Thesis Clerk. All GPS requirements must be met before the thesis will be formally accepted by the library. Guidelines for electronic submission are found at <http://thesis.tamu.edu>. A bound copy of the final thesis should also be given to the student's Advisory Committee.

2. Master of Engineering Report

1. The final copy of the Master of Engineering Report (either intern or special problem) must be typed in an acceptable technical journal format. Final draft copies of the report must be made available to the student's Advisory Committee at the time the final examination is announced (at least two weeks prior to the examination).
2. Results of the final examination will not be reported to the Office of Graduate Studies until all corrections to the report have been made.
3. A copy of the final M.E. report shall be distributed to the student's Advisory Committee.

3. Master of Agriculture Report

The Master of Agriculture report (either intern or special problem) must meet all the criteria outlined above for the Master of Engineering report.

4. Doctor of Philosophy Dissertation

A dissertation in final draft form must be submitted to the graduate committee at least two weeks before the final examination. After the final examination, corrections to the dissertation must be made prior to submitting it to the Thesis Clerk. All requirements of the Office of Graduate Studies must be met before the dissertation will be formally accepted by the library. Guidelines for electronic submission are found at <http://thesis.tamu.edu>. A

bound copy of the final dissertation should also be given to each member of the student's Advisory Committee.

Students are expected to submit evidence that two papers have been submitted for publication or published in a peer-reviewed journal to the Department Head or Graduate Program Chair/Associate Head (by providing the submission acknowledgement(s) from the journal(s), or via filling the Manuscript Tracking Form with the student's major professor's signature) when submitting Written Dissertation Approval Form for signature.

A sample Manuscript Tracking Form could be found under Appendix D or via:

https://tamuag.az1.qualtrics.com/jfe/form/SV_1OchmOGK8GpgZTM

Graduate research is often funded by grants, and the Principal Investigators (PIs) of these grants are tasked with ensuring that all grant-related deliverables are met. For most funders, key deliverables include project reports and peer-reviewed publications. Graduate students engaged in thesis or dissertation research funded by these grants are expected to compile their data and publish their scientific findings in a timely manner, ideally before their graduation. PIs may note in the BAEN Departmental Ph.D. Student Evaluation that the student has agreed to collaborate on submitting/revising the manuscripts in a reasonable amount of time. If a student fails to comply with the above, PIs may proceed to publish the findings with necessary adjustments to fulfill the requirements of the grant deliverables.

Financial Assistance

The department may provide financial support in the form of assistantships. Graduate assistants are selected based on previous academic performance, their ability for handling work assignments with excellence, and their potential for future performance in these areas. Positions are available only to graduate students who are actively pursuing graduate degree programs and who are making satisfactory progress toward their degrees.

The funds come from a variety of sources and the budget varies from year to year. Four types of assistantships are awarded by the department: (1) Graduate Assistant Teaching (GAT), (2) Graduate Assistant Non-Teaching (GANT), (3) Graduate Assistant Research (GAR), and (4) Extension Assistantships.

Ph.D. students should be aware that financial support in the form of an assistantship will be terminated if they have enrolled in more than 100 credit hours without graduating.

Teaching Assistantships

Teaching assistantships are awarded by the department head in consultation with the faculty. They are awarded on a semester-by-semester basis. Teaching assignments are made based upon teaching needs and the expertise of the student. It is desirable for each Ph.D. student in the department to spend at least one semester as a teaching assistant to gain experience. However, many factors such as the number of students, availability of funds, teaching needs and student expertise may prevent some Ph.D. students from serving as teaching assistants.

Research Assistantships

Research assistantships are funded through research grants and contracts in the department and are awarded with the approval of the project leader for each grant.

Extension Assistantships

Extension assistantships are available as part of the extension programs in agricultural engineering. They are awarded with the approval of the project leader for each grant.

Responsibilities

Graduate students with assistantships are employees of the department. Thus, a graduate student must fully understand his/her dual role—that of a student and that of an employee. The assistantship is provided to the student for work to be performed. It is not a scholarship

to go to school or to write a thesis or dissertation. In some instances, the project work may not relate to the thesis/dissertation topic. The terms of a graduate assistantship is one-half time requiring 20 hours of work per week and full-time enrollment each semester; 9 hours in fall and spring, 3 hours each summer session or 6 hours for the 10-week summer session.

Graduate Scholarships

A limited number of competitive departmental scholarships will be awarded to graduate students each year depending on the availability of funds. The BAEN graduate advising office will send out calls for applications (prior to the beginning of fall and/or spring semesters) and the BAEN Graduate Program and Recruiting Committee will select the recipients through a competitive selection process.

International Students

Following are some general procedures for you to proceed smoothly with your education at Texas A&M University. More detailed information can be obtained by contacting the specific university services. The Texas A&M University Office of International Student Services will be an excellent source of helpful and important information and support throughout your academic career. You are encouraged to carefully review the website to learn of all the resources available to you at. <https://global.tamu.edu/iss>

Things to Do Before Arriving On Campus

1. Visa— Once you have received an official letter of admission from the university, you need to contact the U.S. Embassy or Consulate in your home country near you to determine what things you need to do in order to apply for a visa. Upon arrival to the U.S., you will be asked to present your I-20, a valid visa and other pertinent documents to the immigration officer.
2. Housing—for information about housing options, go to <https://reslife.tamu.edu/options/>
3. Initial Expenses—Students should bring about US \$5,000 in funds which can be used immediately for resettling costs (apartment rent, deposits, utilities, and telephone), for opening your bank account and for establishing your household. If you bring bank or personal checks, allow for two weeks processing time at the bank before you will be able to use the money. This is very important because typically all of a student's tuition and fees are due before classes begin each semester.

Educational expenses for nine months will vary according to your personal needs and course of study. The Financial Aid Office's basic budget for new graduate students includes tuition and fees, books, supplies, transportation, room and board, incidental, and living expenses. Total expenses for returning students during an academic year should be slightly less than those for new students. For the latest and detailed tuition and fee information, please refer to <https://sbs.tamu.edu/>

The University offers very few scholarships to new international students. However, there are several scholarships available and administered through International Student Services (ISS) as well as financial assistance information at <https://global.tamu.edu/ea/funding>

4. Health Insurance—Health insurance is required for all international students enrolled at Texas A&M University. Additional information about this requirement can be found at <https://global.tamu.edu/iss/health-and-safety/health-insurance>. It is ultimately the student's responsibility to show proof of insurance.

Other Important Items

English Language Proficiency:

All international students whose native language is not English must fulfill an English proficiency requirement before gaining admission to Texas A&M University. Verification can be met in a variety of ways. For details on requirements visit

Students who will be serving as Graduate Assistants Teaching (GAT) must be English Language *Certified*. Certification can be achieved in a variety of ways. For details on requirements visit

Courses Registration—How and When?—Who Can Help? Your major professor will make recommendations for your first semester courses. Registration is done after you have checked in with ISS and resolved any additional registration holds on a student's file. Pay close attention to tuition payment due dates.

Payroll and Financial Aid - If you are given an assistantship, you should immediately see the Business Manager to start paper work promptly. You will be requested to attend an Orientation session at the Human Resources Office.

Other sources of financial aid are available for students. Details can be found at <https://scholarships.tamu.edu/>. The BAEN department encourages all students to visit the departmental website which also contains information regarding funding opportunities <https://baen.tamu.edu/academics/graduates/>.

Orientation -

The Graduate and Professional School provides an incoming student orientation that can be very helpful to new students. <https://grad.tamu.edu/knowledge-center/dates-and-deadlines/new-graduate-student-orientation>

A more detailed document on "Orientation Guide for New Graduate Students could be found under Appendix F.

Texas driver's license or ID - You should get either a Texas driver's license or a Texas ID. Either document is used in many kinds of daily transactions and activities such as paying by check or as an identity card. It is not safe to walk around with your passport! You should go to the local Texas Department of Public Safety (DPS), 2571 N. Earl Rudder Fwy., Bryan TX 77803, 979-776-3110 (phone).

Appendix

This appendix is to be used as a guide and the information is subject to change; please consult with the graduate academic advisor for the most up to date information.

Appendix A – Degree Requirements: Quick Reference

Master of Science in BAEN Degree Requirements (thesis option)

| Course | Number of Courses | Total Credit Hours |
|---|-------------------|--------------------|
| BAEN 681: Seminar | 1 | 1 |
| BAEN 690: Theory of Research | 1 | 1 |
| BAEN 683: Peer Review Process and Publication | 1 | 1 |
| BAEN 691: Research | *** | 8** |
| BAEN Elective courses | 2 | 6 |
| MATH Elective | 1 | 3 - 4 |
| STAT Elective | 1 | 3 - 4 |
| Free Electives | *** | 7 - 9 |
| Total Hours | | 32** |

**Must choose MATH and STAT elective from approved course list. See reference list. Student can only have a maximum of 6 hours of 685 and 689 combined coursework on graduate degree plan. Maximum of 9 hours of undergraduate credit at the 300-400 level may be used on a graduate degree plan. None of the BAEN undergraduate required courses may be used on a graduate degree plan. Student may only apply a maximum of 12 hours of transfer coursework to a graduate degree plan. Final oral defense of thesis required.*

***Students entering the department after Fall 2019 will be placed on a 30 hour degree program requiring no more than 6 hours of research credits.*

Master of Science in AGSM Degree Requirements (thesis option)

| Course | Number of Courses | Total Credit Hours |
|--|-------------------|--------------------|
| BAEN 681: Seminar | 1 | 1 |
| BAEN 690: Theory of Research | 1 | 1 |
| BAEN 683: Peer Review Process and Publication | 1 | 1 |
| BAEN 691: Research | *** | 8 |
| BAEN Elective courses | 2 | 6 |
| BAEN 601: Advanced Agricultural Systems Analysis | 1 | 3 |
| STAT Elective | 1 | 3 - 4 |
| Free Electives | *** | 8 - 9 |
| Total Hours | | 32 |

**Must choose STAT elective from approved course list. See reference list. Student can only have a maximum of 6 hours of 685 and 689 combined coursework on graduate degree plan. Maximum of 9 hours of undergraduate credit at the 300-400 level may be used on a graduate degree plan. None of the AGSM undergraduate required courses may be used on a graduate degree plan. Student may only apply a maximum of 12 hours of transfer coursework to a graduate degree plan. Final oral defense of thesis required.*

Master of Science in AGSM Degree Requirements (non-thesis option)

| Course | Number of Courses | Total Credit Hours |
|--|-------------------|--------------------|
| BAEN 681: Seminar | 1 | 1 |
| BAEN Elective courses | 2 | 6 |
| BAEN 601: Advanced Agricultural Systems Analysis | 1 | 3 |
| Free Electives | *** | 26 |
| Total Hours | | 36 |

** Student can only have a maximum of 6 hours of 685 and 689 combined coursework on graduate degree plan. Maximum of 9 hours of undergraduate credit at the 300-400 level may be used on a graduate degree plan. None of the AGSM undergraduate required courses may be used on a graduate degree plan. Student may only apply a maximum of 12 hours of transfer coursework to a graduate degree plan.*

Master of Engineering in BAEN Degree Requirements

| Course | Number of Courses | Total Credit Hours |
|-----------------------------------|-------------------|--------------------|
| BAEN 681: Seminar | 1 | 1 |
| BAEN 684: Professional Internship | *** | 3 - 6 |
| BAEN Elective courses | 2 | 6 |
| MATH Elective | 1 | 3 - 4 |
| Free Electives | *** | 13 - 17 |
| Total Hours | | 30 |

**Must choose MATH elective from approved course list. See reference list. Student can only have a maximum of 6 hours of 685 coursework on graduate degree plan. Any combination of 684 and 685 cannot exceed 25% of total hours. Maximum of 9 hours of undergraduate credit at the 300-400 level may be used on a graduate degree plan. None of the BAEN undergraduate required courses may be used on a graduate degree plan. Student may only apply a maximum of 12 hours of transfer coursework to a graduate degree plan. Final oral examination over written internship report required.*

Doctorate of Philosophy in BAEN Degree Requirements (96 credit hour option) – students with no MS degree

| Course | Number of Courses | Total Credit Hours |
|---|-------------------|--------------------|
| BAEN 681: Seminar | 1 | 1 |
| BAEN 690: Theory of Research | 1 | 1 |
| BAEN 683: Peer Review Process and Publication | 1 | 1 |
| BAEN 691: Research | *** | 60 |
| BAEN Elective courses | 2 | 6 |
| MATH Elective | 1 | 3 - 4 |
| STAT Elective | 1 | 3 - 4 |
| Free Electives | *** | 19 - 21 |
| Total Hours | | 96 |

**Must choose MATH and STAT elective from approved course list. See reference list. Student can only have a maximum of 3 hours of 685 coursework on graduate degree plan. Student must complete preliminary examination (written and oral). Final oral defense of dissertation required.*

Doctorate of Philosophy in BAEN Degree Requirements (64 credit hour option) – students with a MS degree

| Course | Number of Courses | Total Credit Hours |
|---|-------------------|--------------------|
| BAEN 681: Seminar | 1 | 1 |
| BAEN 690: Theory of Research | 1 | 1 |
| BAEN 683: Peer Review Process and Publication | 1 | 1 |
| BAEN 691: Research | *** | 40 |
| BAEN Elective courses | 2 | 6 |
| MATH Elective | 1 | 3 - 4 |
| STAT Elective | 1 | 3 - 4 |
| Free Electives | *** | 7 - 9 |
| Total Hours | | 64 |

**Must choose MATH and STAT elective from approved course list. See reference list. Student can only have a maximum of 3 hours of 685 coursework on graduate degree plan. MATH and STAT requirement can be waived if student obtained a grade of B or better in an approved course while obtaining MS degree. Student must complete preliminary examination (written and oral). Final oral defense of dissertation required. Student who obtained MS degree in department and satisfactorily completed BAEN 690 does not have to retake course.*

Master of Science in AGSM Degree Requirements DISTANCE

| Course | Number of Courses | Total Credit Hours |
|--|-------------------|--------------------|
| BAEN 601: Advanced Agri Sys Analysis | 1 | 3 |
| BAEN 620: Food Rheology | 1 | 3 |
| BAEN 622: Unit Operation in Food Proc | 1 | 3 |
| BAEN 625: Advances in Food Eng | 1 | 3 |
| BAEN 627: Engr Aspects Food Pkg | 1 | 3 |
| BAEN 685: Special Topics Shelf life Princ and Apps | 1 | 3 |
| STAT 651 | 1 | 3 |
| Food Science or Free Electives | *** | 15 |
| Total Hours | | 36 |

| Course | Number of Courses | Total Credit Hours |
|--|-------------------|--------------------|
| BAEN 625: Advances in Food Eng | 1 | 3 |
| BAEN 685: Special Topics Shelf life Princ and Apps | 1 | 3 |
| | 1 | 3 |
| | 1 | 3 |
| BAEN 662: Unit Operation in Food Proc. | 1 | 3 |
| BAEN 601: Advanced Agri Sys Analysis | 1 | 3 |
| BAEN 627: Engr Aspects Food Pkg | 1 | 3 |

| | | |
|--------------------------------|-----|---------|
| BAEN 620: Food Rheology | 1 | 3 |
| STAT Elective | 1 | 3 - 4 |
| Food Science or Free Electives | *** | 9 |
| Total Hours | | 36 - 37 |

**Must choose STAT elective from approved course list. See reference list. Student can only have a maximum of 6 hours of 685 and 689 combined coursework on graduate degree plan. Maximum of 9 hours of undergraduate credit at the 300-400 level may be used on a graduate degree plan. None of the AGSM undergraduate required courses may be used on a graduate degree plan. Student may only apply a maximum of 12 hours of transfer coursework to a graduate degree plan. Final oral defense of thesis required.*

Master of Engineering in BAEN Degree Requirements DISTANCE

| Course | Number of Courses | Total Credit Hours |
|--|-------------------|--------------------|
| BAEN 620: Food Rheology | 1 | 3 |
| BAEN 622: Unit Oper in Food Proc | 1 | 3 |
| BAEN 625: Advances in Food Eng | 1 | 3 |
| BAEN 627: Engr Aspects Food Pkg | 1 | 3 |
| BAEN 684: Professional Internship | *** | 3 - 6 |
| BAEN 685: Special Topics Shelf life Princ and Apps | 1 | 3 |
| MATH Elective | 1 | 3 - 4 |
| Food Science or Free Electives | *** | 9 |
| Total Hours | | 30 - 34 |

| Course | Number of Courses | Total Credit Hours |
|-----------------------------------|-------------------|--------------------|
| BAEN 625: Advances in Food Eng | 1 | 3 |
| BAEN 684: Professional Internship | *** | 3 - 6 |
| BAEN 620: Food Rheology | 1 | 3 |
| BAEN 627: Engr Aspects Food Pkg | 1 | 3 |
| BAEN 622: Unit Oper in Food Proc | 1 | 3 |
| BAEN 685: Special Topics | 1 | 3 |

| | | |
|--------------------------------|-----|---------|
| | 1 | 3 |
| MATH Elective | 1 | 3 - 4 |
| Food Science or Free Electives | *** | 6 |
| Total Hours | | 30 - 34 |

**Must choose MATH elective from approved course list. See reference list. Student can only have a maximum of 6 hours of 685 coursework on graduate degree plan. Any combination of 684 and 685 cannot exceed 25% of total hours. Maximum of 9 hours of undergraduate credit at the 300-400 level may be used on a graduate degree plan. None of the BAEN undergraduate required courses may be used on a graduate degree plan. Student may only apply a maximum of 12 hours of transfer coursework to a graduate degree plan. Final oral examination over written internship report required.*

Appendix B – Sample Internship Documentation Form

(This form must be completed and returned to BAEN Graduate Advising Office before leaving for internship)

| |
|--|
| Student Information |
| Student name: |
| UIN: |
| Major: |
| Internship Information |
| Company/organization name: |
| Supervisor name and contact information: |
| Company/organization location: |
| Hours planned per week: |
| Length of internship (weeks): |
| Semester/year of internship: |
| Topic: |
| Objectives: |
| Student Signature: _____ |
| Faculty Signature: _____ |

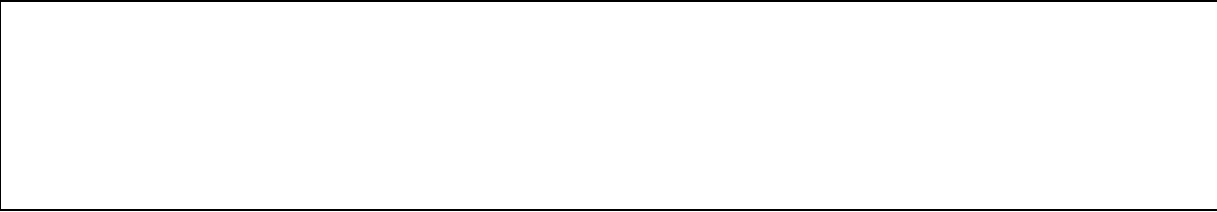

Appendix C – Annual PhD Student Progress Form

Biological and Agricultural Engineering (BAEN) Department

Annual Ph.D. Student Progress Form

Return to BAEN Graduate Office by May 01 Annually

(Note: Failure to turn this in by the deadline will result in an academic registration hold)

1. (To be completed by the student)

Student Name: _____ ID Number: _____

Email Address: _____ Phone: _____

Date of First Enrollment in the PhD Program (semester/year) _____

Expected date of defense (semester/year) _____

Graduate Credit Hours completed during PhD study at Texas A&M: _____ CGPA: _____

Name of the Committee Chair: _____

Co-Chair: _____

Milestones Completed

Dissertation/Advisory Committee Formed _____ (date)

Members: _____

Dissertation Proposal Title: _____

Oral Prelim Exam

Date Taken _____ Passed ___ Failed ___ (First try)

Date Taken _____ Passed ___ Failed ___ (Second try if necessary)

Advanced to Candidacy (Date) _____

2. (To be completed by the student)

Main Area of Research / Interest: _____

Progress Summary

Please write a short summary of your progress in the PhD Program over the past 12 months. Include accomplishments such as papers submitted or accepted, conferences attended, honors and awards, or any other significant event(s). You should also mention any problems in making progress on your degree.

3. (To be completed by the Committee Chair)

Overall progress (check)

Satisfactory: _____ Needs Improvement: _____ Unsatisfactory: _____

Remarks (use this space to set goals for upcoming year, elaborate unsatisfactory performance etc.

Signature of Student: _____

Signature of Committee Chair: _____

Appendix D – Sample Manuscript Tracking Form

This form must be completed and submitted with the Written Dissertation Approval Form when obtaining Department Head signature. PhD level - the expectation is two submitted manuscripts

| |
|--|
| Student Information |
| Student Name: |
| UIN: |
| Major: |
| Manuscript #1 information |
| Title of Manuscript: |
| Journal Title: |
| Date Submitted: |
| Authors: |
| Student Signature: _____ Faculty Signature: _____ |
| Manuscript #2 information |
| Title of Manuscript: |
| Journal Title: |
| Date Submitted: |
| Authors: |
| Student Signature: _____ Faculty Signature: _____ |

Appendix E – Deadlines for completing degree requirements

The Associate Department Head for Academic Affairs will be responsible for tracking student progress through the degree program and will provide timely notices of approaching deadlines. Failure to comply with degree program requirements may result in blocked registration. A student may request an extension of a deadline by written request from the student and Major Professor to the Director of Graduate Programs and the Department Head.

| REQUIREMENT | COMPLETION SEMESTER [¥] | |
|----------------------------------|---|---|
| | M.S. | Ph.D. |
| Identify Major Professor | 1 st | 1 st |
| Committee Formation [♯] | 2 nd | 3 rd |
| Degree Plan [☼] | 2 nd | 4 th |
| Research Proposal Submitted | 3 rd | 5 th |
| Preliminary Exam | - | 7 th |
| Exit Seminar | Last Semester | Last Semester |
| Final Exam | Established by Major Professor, and Committee | Established by Major Professor, and Committee |

¥ *Times are semesters after first enrollment and **exclude summer semesters.***

☼ *This requirement is mandated by the College of Agriculture and Life Sciences and non-compliance will result in blocking from registration.*

♯ *Annual Committee meetings are expected to ensure appropriate student progress toward degree. For doctoral students, these requirements will be monitored via graduate annual reports to the Director/ Associate Head of Graduate Programs.*

Appendix F – Facilities and Resources

The BAEN department has state-of-the-art facilities, resources, and equipment to help facilitate the teaching and research enterprise. In addition to the departmental resources, there are numerous core facilities across the campus focused on the thematic areas of integrated biological and medical translational research, microscopy and imaging materials and fabrication, chemical science technologies, and data informatics and computation. Key BAEN-controlled facilities and resources available for the graduate program are discussed below.

Biomolecular and Biochemical Engineering Laboratory (Scoates 219 & 220; PI: Dr. Maria King)

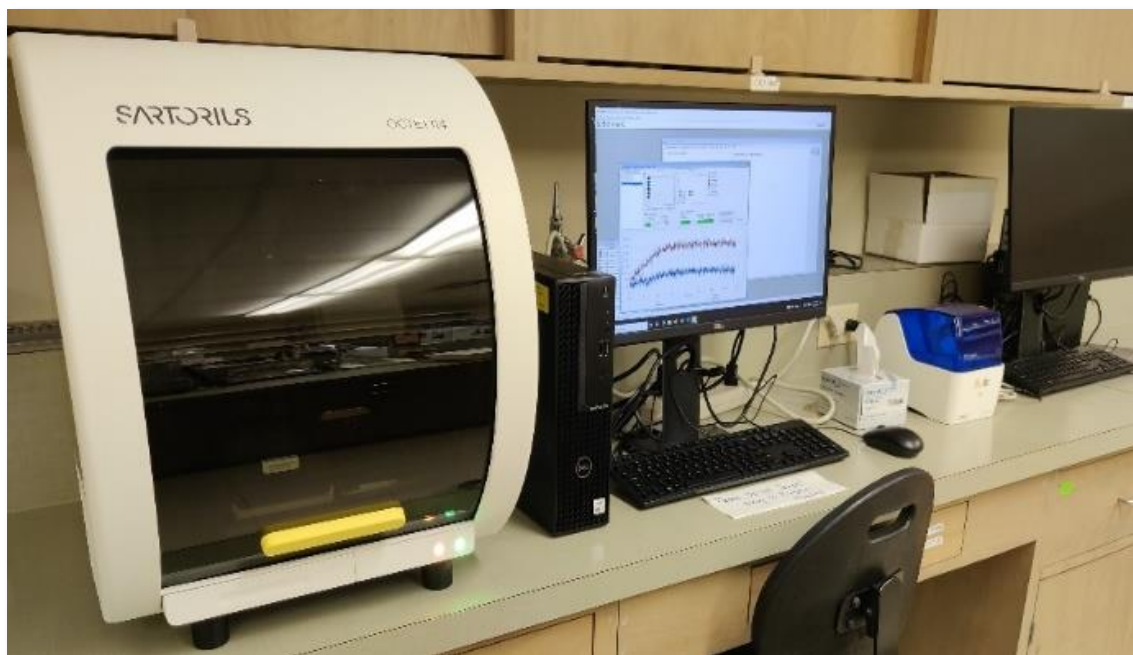

Figure F1: Scoates 219

Scoates 219 is equipped for characterization of synthetic and recombinant biomolecules using a label-free biomolecular interaction analysis based on biolayer interferometry (Octet BLI), as well as plate reader and spectrophotometer.

Scoates 220 is equipped with all standard biochemical process equipment (shaking incubator, autoclave, biosafety cabinet, -80°C freezer, incubators, benchtop centrifuge, sonicator, high-shear mixer rotavapor, and water baths) for growth and cultivation of recombinant and native microorganisms (*E. coli*). Both rooms are BL2 certified.



Figure F2: Scoates 220

Bioseparations Laboratory (Scoates 221; PI: Dr. Zivko Nikolov)

The Bioseparations Lab is used for transformative research in bioprocess engineering aimed at development of novel and cost-effective strategies for extraction and purification of recombinant and native biomolecules. Research focuses on bioprocesses for production and separation of recombinant enzymes, therapeutic proteins, and other high-value bioproducts produced by bacteria, microalgae and mammalian cell. Bioseparations lab personnel also have expertise in protein purification and bioprocess design.

Bioprocessing and separation-related equipment include a homogenizer, a refrigerated high-speed centrifuge, an AKTA Purifier, an electrophoreses and blotting apparatus, membrane filtrations systems for bench and pilot-scale filtration, and variety of peristaltic pumps.



Figure F3: Scoates 221

Food Engineering Laboratory (Scoates 316; PI's: Dr. Rosana Moreira and Dr. Elena Castell-Perez)

The Food Engineering Laboratory is dedicated to teaching and research activities in food and bio- process engineering. Current research focuses on characterization of nanoparticles for use in delivery of antioxidant and antimicrobial natural agents using spectrophotometry, particle size analysis and other analytical methods.



Figure F4: Food Engineering Laboratory (Scoates 316)

Instructional equipment in this laboratory includes a concentric tube heat exchanger for pipe flow and heat transfer demonstrations, a high temperature shot time pasteurizing system, a tray dryer for study of psychrometrics, scales, headspace and pH meters, digital hygrometers, thermal conductivity and diffusivity probe, moisture content and water activity meters. Instructional equipment is used primarily in undergraduate courses in both the BAEN and AGSM curricula.

Biological Material Properties Laboratory (Scoates 144; PI's: Dr. Rosana Moreira and Dr. Elena Castell-Perez)

The primary focus of this lab is the characterization of the behavior of food and biological materials to understand the impact of processing and formulation on final product quality and functionality.

Research activities focus on improved functionality, rheology of biopolymeric solutions and nanocomplexes for drug delivery, gelling quality of insect-based proteins, properties of polymeric film packaging materials, 3D printed bioproteins and other biomaterials, and mechanical properties of fibers (cotton, meat).

Pertinent equipment in the laboratory include colorimeter, texture analyzers, differential scanning calorimeter, centrifuges, tensiometer, Brookfield viscometers, capillary viscometers, falling ball viscometers, two controlled stress rheometers, powder flow rheometer, 3D printer, and an HPLC.



Figure F5: Biological Material Properties Lab (Scoates 144)

Food Engineering Laboratory (Scoates 314; PI's: Dr. Rosana Moreira and Dr. Elena Castell-Perez)

This laboratory is used for research on basic food processing technologies such as vacuum frying, drying, vacuum impregnation, and baking. Food and bioprocessing research involve application of engineering and science to the optimization and design of food processing systems. Areas of research focus on modeling and automatic control of deep-fat frying, vacuum frying, vacuum impregnation, impingement drying, and dehydration, development of nanomaterials for nutrient delivery and other applications, and product and packaging testing via shelf-life studies. The laboratory houses a vacuum-fryer, vacuum impregnation system, oil testing Soxhlet unit, product specific gravity and density tools, fume hoods, rotavapor unit, incubators, pH meters, and moisture content ovens.



Figure F6: Food Engineering Laboratory (Scoates 314)

Mechatronics and Controls Laboratory (Scoates 318; PI: Dr. Bobby Hardin)

This 935 ft² room is dedicated to teaching electronics, mechatronics, controls, and electricity courses. There are twelve networked workstations equipped with computers and a networked printer. This laboratory was renovated in 2014 to upgrade workstation furniture and the computers were upgraded in 2019.



Figure F8: Mechatronics and Controls Laboratory (Scoates 318)

Nanoscale Biological Systems Laboratory (Scoates 147; PI: Dr. Sandun Fernando)

The primary focus of the Nanoscale Biological Engineering Laboratory is to understand how molecules of biological origin interact with other molecules, surfaces, and interfaces. Biological systems thrive as a result of complex intermolecular interactions and deciphering these will help engineer/control products and processes that are critical to agriculture and improving our health.

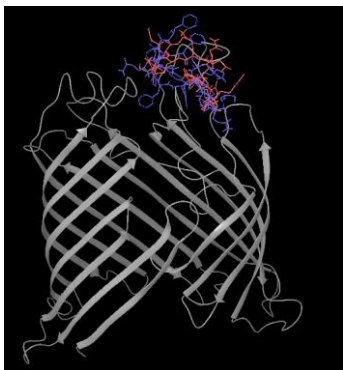

Figure F9: Several peptides engineered in our lab blocking an efflux pump of an antibiotic-resistant bacteria

We utilize molecular dynamic simulation-assisted techniques for **designing** molecules and processes at a molecular level, followed by experimental verification. We use Enhanced Ligand Exploration and Interaction Recognition Algorithm (ELIXIR-A), a platform developed in our laboratory along with other simulation software to analyze intermolecular interactions for underpinning interaction points. We use these interaction points to design molecules with the necessary chemical/physical functionality. Using the above techniques, we have developed molecules with novel properties such as adaptability to changing chemical environments and catalytic/inhibitory functionality. The laboratory collaborates with scientists of different backgrounds

to carry out this highly interdisciplinary work.

Some example projects that we continue to be involved in include:

- Design of novel self-adaptive molecules with enzyme inhibitory properties (drugs)
- Bottom-up design of peptides and aptamers (for drug and biosensing applications)
- Catalysis (bioenergy, fuel cells)
- Surface functionalization (SAMs, separations)

The Nanoscale Biological Engineering Laboratory is equipped with state-of-the-art analytical instruments, including an Atomic Force Microscope, Pyroprobe-coupled GCMS, Particle/zeta sizer, FTIR, UV-Vis spectrometer, GC, HPLC, TGA, and various reactors (high-pressure hydrothermal reactor, continuous reactor, ultrasonic reactor and a high-pressure homogenizer).

CAAQES - Aerosol Technology Laboratory (ATL) (Scoates 324, PI: Dr. Maria King)

The CAAQES-ATL Laboratory addresses the needs for improved monitoring of public health emergencies by focusing on the collection, detection and tracking of hazardous bioaerosols including infectious particles with antimicrobial resistance using the autonomous wetted wall cyclone (WWC) collector system developed in ATL.

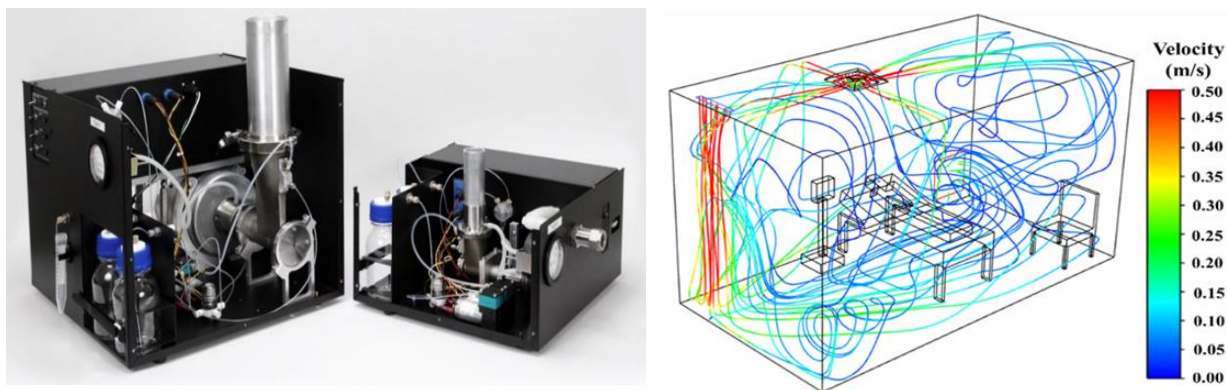

Fig F-10: The focus of the research program is to combine aerosol collection and microbiome analysis with particle tracking velocimetry and computational fluid modeling, biolayer interferometry and molecular dynamics simulation to visualize ventilation airflow patterns and study the effect of environmental factors and surfaces on aerosol resuspension, infectivity, and resistance.

The bioaerosol (fungi, bacteria, viruses, and toxins) collections are conducted in industrial, agricultural, urban, and mass transport areas, including hospitals, portable classrooms, dairy barns, chicken coops and meat processing facilities. Our broader interest covers the development and testing of airborne nanoparticle monitoring systems and radionuclide emission surveillance in nuclear facilities. The ATL laboratory is an internationally recognized testing facility to certify that the performance of radionuclide samplers and probes conforms with the American National Standards Institute (ANSI)HPS N13.1-1999/2011 standards. Some example projects that we continue to be involved in include:

- Environmental Effects on Viable Virus Transport in Ventilation Airflow at High-Risk Facilities (WWC bioaerosol collection, ANSYS Fluent modeling)
- Virus - Receptor Interactions (Biolayer interferometry, molecular dynamics design)
- Antimicrobial Resistance in Aerosolized Bacteria (Electron microscopy, whole genome sequencing)
- Resuspension of Radioactive Aerosols (Atomic Force Microscopy, LAMMPS simulation)
- Measurement of Emission Factors for Cotton Gin Trash Piles

The CAAQES - Aerosol Technology Laboratory is equipped with state-of-the-art analytical instruments, including a high-speed wind tunnel, a BSL2 biosafety cabinet, incubators, autoclave, fluorescent spectrophotometers, Coulter Counter and Aerodynamic Particle (APS) sizers, WWC bioaerosol collectors, conventional and real-time polymerase chain reaction thermocyclers and molecular biology equipment and supplies. In addition, a ventilated hospital chamber with twelve PM2.5 samplers and a wind tunnel are available.

Bio-Energy Testing and Analysis Laboratory (BETA) (Hobgood 109, PI: Dr. Sergio Capareda)



Figure F-11: Hobgood 109

The Bio-Energy Testing and Analysis Laboratory (BETA Lab: <https://betalab.tamu.edu>) has a complete set of testing and analysis facility for biomass, biofuels, renewable energy and air quality. The objectives of the BETA Lab are to conduct::

1. Process design optimization work in all aspects of biomass conversion and bio-fuel production
2. Performance testing of engines fueled by biomass-based fuels
3. Air quality and emissions testing for bio-conversion technologies
4. Renewable energy tests involving solar, wind and other renewable energy sources
5. Carbon footprint research and documentation

Flexible Laboratory (Hobgood 109)

Additional area in Hobgood 109 is devoted to operation of pilot facilities for biomass thermal pyrolysis and gasification research including biofuels characterization. The lab has complete sets of facilities and equipment for biomass and biofuels characterization with most parameters following ASTM Standards. The laboratory has mobile gasifier for synthesis gas, biochar and power production from various biomass feedstocks.

Texas Food Safety Engineering Laboratory (Hobgood 115; Pls: Dr. Rosana Moreira and Dr. Elena Castell-Perez)

This facility houses a 2 MeV Van de Graaff Accelerator that can generate current up to 250 μA of electrons at specific selected energies between 0.75 and 2 MeV. At the highest energy, 2 MeV, the beam power can be adjusted to 100 watts and delivered to a target area of 100 square centimeters of unit density of material, providing a dose of 1.0 kGy.

Research includes food irradiation of complex shaped materials, use of Monte Carlo and CAT scan techniques for dose calculation, chemical phantom sensors for dose measurement, modeling of kinetics of food components degradation during radiation, modeling of microorganisms destruction during food irradiation, irradiation of polymeric materials for smart packaging and improved mechanical properties, and irradiation to improve energy efficiency as pre-treatment of bio- mass for ethanol production, and irradiation thermal-cracking for distillation of heavy oils.



Figure F-12: Food Safety Engineering Laboratory (Hobgood 115)

Post Harvest Engineering and Education Laboratory (Hobgood 115 and 108; PI: Dr. Janie Moore)

The primary focus of the Post-Harvest Engineering and Education (PHEED) Laboratory is to understand how treatment technologies can be used to improve and advance agro-industrial biomass. Protecting our food and feed supplies from postharvest losses is critical to increasing food availability, and postharvest handling and storage is a significant contributor to food waste.

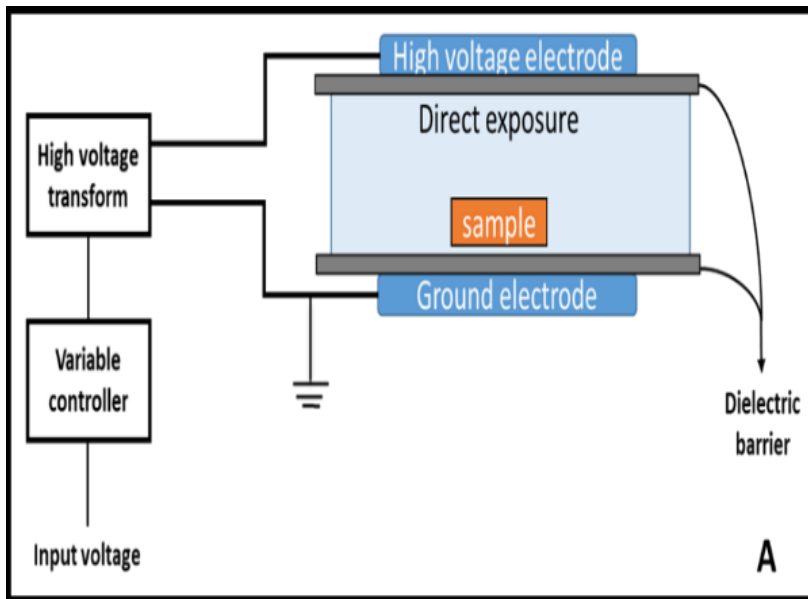

Figure F-13: Atmospheric Cold Plasma system with power input, high voltage, and dielectric barriers. Plasma image with system at 70kV, visible RGS creation.

We use reactive gas species, generated by atmospheric cold plasma (ACP), to destroy and degrade biological material bonds. This research is designed to increase scientific understanding of ACP and ozone treatment of stored grains, provide a model for managing aflatoxin and spoilage in stored grains, and strategies for treatment levels once aflatoxin contamination is identified, thereby minimizing disruptions in feed stock business and trade. Our team works

to create baselines for ACP and ozone treatments of stored grain commodities that are frequently contaminated with deadly aflatoxins, and we will make this information available to grain processors and community stakeholders.

Among the projects in which we are still involved are:

- Microbiological activity reduction treatment for stored grains and oilseeds
- Pest control for stored grains using Atmospheric Cold Plasma
- Agroindustrial biomass depolymerization and valorization
- Assessment of persistence in engineering education for students from underrepresented groups

This PHEED Laboratory is equipped with standard equipment for post-harvest quality analysis of grains and cereals (i.e., moisture content, water activity, fat acidity, mycotoxin rapid test kit). The lab is equipped with an ozone generator (0-2000ppm) and an ozone

analyzer. The laboratory houses the Atmospheric Cold Plasma system, the main components of the ACP reactor. The dielectric barrier ACP system was built by using the AC Dielectric Test set (Phenix Technologies, Accident, MD). The input reading is 110-120 volts, single phase, 50/60 Hz, and 30 amperes. The output kilovolts are 0-120 kilovolts, 125 milliamperes and is operated by a variable controller and power system. The ACP system has been estimated to have a power consumption cost of \$0.05-0.10/kWh, with small-scale treatments generally requiring less than 600s per package. The system also includes an optical emission spectroscopy system to analyze emissions from the ACP system and record them in a computer for analysis of RGS created during treatment. The laboratory is also equipped with UV-Vis spectrometer, FTIR, and uHPLC. For educational assessment, the laboratory has nVivo a qualitative data analysis software package produced by QSR International.

Hydrology and Ecosystem Sustainability (Virtual) Laboratory (PI: Dr. Salvatore Calabrese)

The Hydrology and Ecosystem Sustainability Laboratory addresses critical environmental challenges arising from the impact of climatic changes and land management practices on the hydrologic cycle and the spatiotemporal dynamics of carbon and nutrient cycles in the soil and throughout the Critical Zone. Our multidisciplinary approach seamlessly integrates hydrology, biology, biogeochemistry as well as dynamical system theory, stochastic processes, and thermodynamics, allowing us to holistically study the interaction between human activities and the ecosystems.

We develop mathematical models using Python or R programming language for to simulate hydrological, vegetation, and biogeochemical dynamics across environmental conditions (e.g., rainfall gradients) and human activities (e.g., agricultural practices). Our activities are leading to advanced agricultural management and improved predictions of the effects of climate change on soil and water resources. We also use these simulation models in our graduate classes and in most of our research projects. Models are always freely available in our lab website or public repository (for example, GitHub).

Our team works on multiple interconnected research themes and projects with the ultimate goal of understanding the link between the hydrologic cycle and biogeochemical cycles across natural and agro-ecosystems and multiple spatiotemporal scales to better manage water and soil resources in the context of global changes. These include:

- Ecosystem dynamics in response to global change
- Sustainable agricultural management
- Interconnection between soil water and carbon cycling
- Soil microbial metabolism and thermodynamics

The team currently consists of two Ph.D. students, two Postdoctoral Research Associates, and multiple rotating undergraduate researchers.

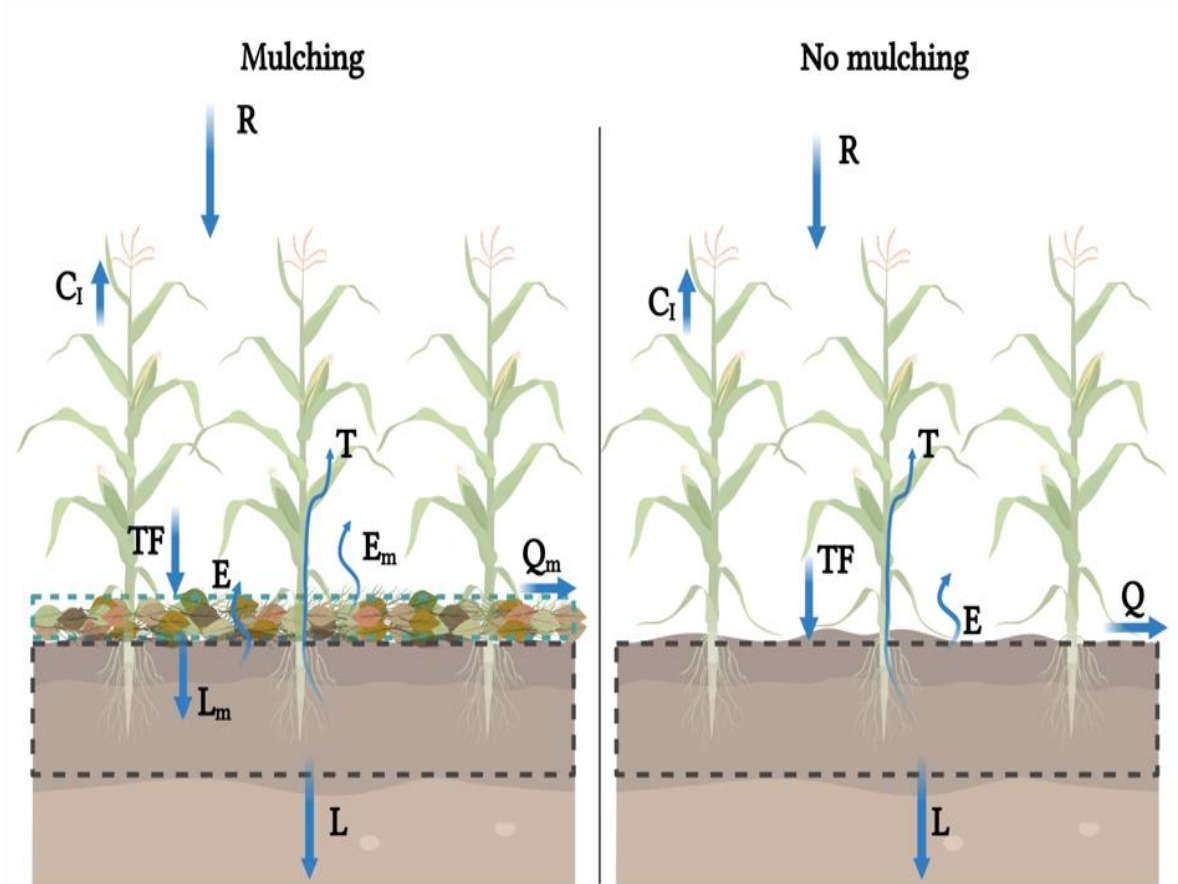

Figure F-14: Schematic representation of the effect of soil mulching (an agricultural practice) on soil hydrology. The Figure is from our peer-reviewed article: Souza, Rodolfo, Achla Jha, and Salvatore Calabrese. "Quantifying the hydrological impact of soil mulching across rainfall regimes and mulching layer thickness." Journal of Hydrology 607 (2022): 127523.

WEF Nexus Research Group (PI: Dr. Rabi Mohtar)

Hydrostructural Pedology is a new paradigm in soil science that grew naturally from the application of systems theory to soil science by addressing not only the organization of soil in the landscape (soil mapping), but also the hierarchical internal organization of the soil medium.

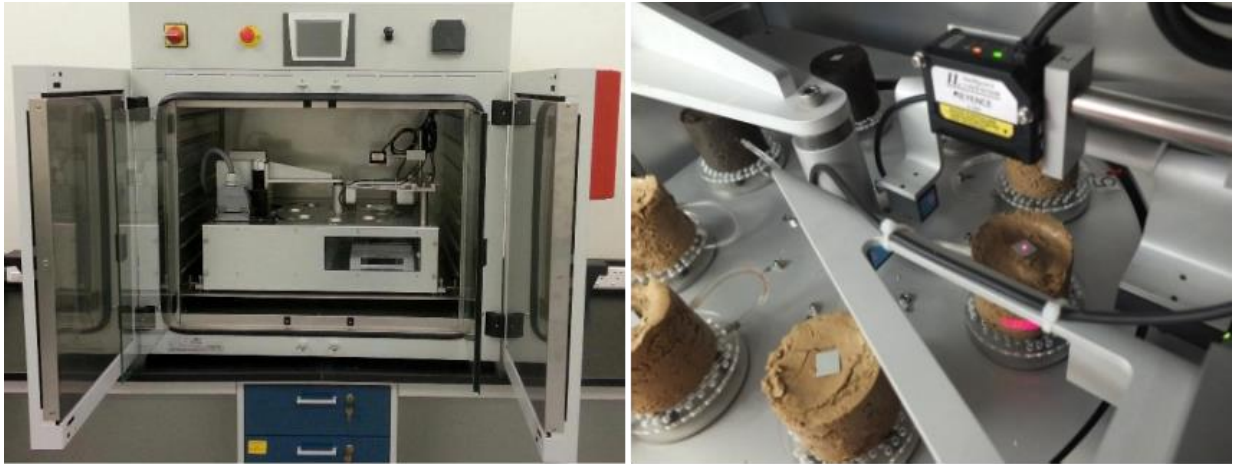

Figure F-15: Typosoil® Apparatus (Soil cores represent the pedostructure of soil horizon)

Pedostructure is like the 'motor' of the soil whose fuel is pedostructural water. The hydrostructural properties of the pedostructure depend on the thermodynamic interaction between water and the surface charges of soil particles, organics, and minerals constituting the non-rigid structure of the soil. These thermodynamic interactions can be characterized by four curves:

- The pedostructure water retention curve, $h=f(Wps)$,
- The pedostructural hydraulic conductivity curve, $kps=f(Wps)$,
- The pedostructural shrinkage curve, $V=f(Wps)$,
- The pedostructural swelling curve, $V=f(t)$.

In the **hydrostructural pedology** laboratory we can characterize the pedostructural characteristics of each soil horizon and organize the data in relation to field operations (soil sampling, mapping, experiments) and the geo- referenced soil information system.

Robotics and Intelligent Systems Laboratory (Urban Ag Building, Dallas #328 PI: Dr. Azlan Zahid (Texas A&M AgriLife Research))

The primary goal of the Robotics and Intelligent Systems Laboratory is to provide Artificial Intelligence (AI)-driven automation solutions to the problems involved in Controlled Environment Agriculture, including high tunnels, greenhouses, vertical farms (multi-tier/ tower walls), plant factories, and other indoor production environments with different growing methods such as soil-based, substrate-based, hydroponics, aeroponics, aquaponics. The work includes robotics, computer vision, edge computing, internet of things (IoT), and microclimate control (light, temperature, CO₂, humidity, air, rootzone, and optimizing control setpoints for efficient microclimate recipe for high-value crops.

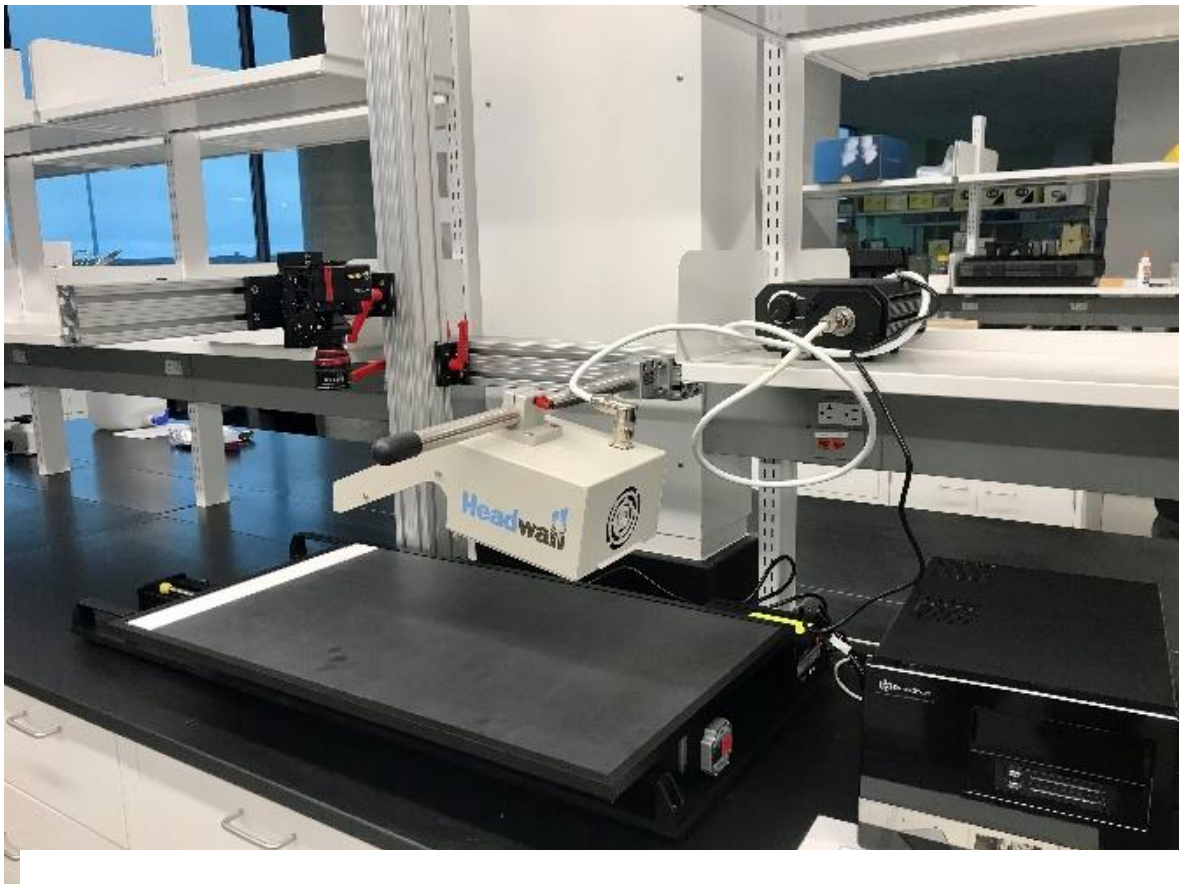

Figure F-16: Robotics and Intelligent Systems Laboratory

Controlled Environment Agriculture is a complex dynamic production system; many factors such as assessing the optimal control setpoints at different growth stages of the crops need to be realized to produce uniform, high quantity, and quality crops. We aim to integrate the AI-driven crop growth predictions, microclimate, sensors, and controllers to achieve the desired microclimate set points for the crop at each growth stage. We have developed a local gateway system to transmit the sensed data wirelessly to the cloud database (AWS: Amazon Web Services) to establish a local host dashboard for data display

and analysis. We exploit AI algorithms to derive empirical and non-linear 'growth response functions' that map microclimate conditions to crop growth stages. We use PLC controllers to achieve the desired control setpoints remotely. We also focus on developing integrated robotic systems, including end-effectors and manipulators, to perform different production operations such as transplanting, monitoring, spraying, and harvesting. The Laboratory collaborates with scientists of different backgrounds, including agriculture (horticulture, plant pathology, entomology) and engineering (mechanical, electrical, computer), to carry out this highly interdisciplinary work.

Some example projects that we continue to be involved in include:

- AI-driven greenhouse microclimate monitoring and control system
- End-to-end deep learning-based crop growth prediction models for yield monitoring
- Edge-AI for non-invasive crop stress monitoring and management system
- Develop integrated robotic end-effector and manipulator for crop management
- Cyber-Physical-Systems for automatic irrigation monitoring and controls

The Laboratory is equipped with state-of-the-art instruments, including a hyperspectral camera (600 nm to 1700 nm), multispectral camera, RGB-Depth cameras, dual nozzle 3D printer, LoRaWAN indoor and outdoor gateways, LoRaWAN field tester, and various high-speed workstations including hyperspectral data processing unit, NVIDIA Jetson Xavier and Nano, and high-end workstation with 48 GBs NVIDIA Graphic Processing Unit (GPU).

Appendix G – Orientation Guide for New Graduate Students

Welcome to the Biological and Agricultural Engineering (BAEN) Department at Texas A&M University! As you embark on your graduate studies, it's essential to familiarize yourself with various resources and procedures to ensure a smooth transition. Below is a guide to assist both domestic and international graduate students in settling into life at Texas A&M University.

1. University Orientation and Resources

- **New Graduate Student Orientation (NGSO):** Texas A&M hosts NGSO at the beginning of each semester to welcome new graduate and professional students. This orientation provides an overview of campus services, academic expectations, and opportunities to connect with fellow students. For details on upcoming sessions and registration, visit the Graduate and Professional School's orientation page: [Texas A&M University Graduate Studies](#).
- **International Student & Scholar Services (ISSS):** ISSS supports international students and scholars as they navigate the U.S. immigration system and life in the U.S. They offer guidance on policies, regulations, and provide programs to enhance the international community experience at Texas A&M. More information is available on the ISSS website: [Texas A&M University Global](#)

2. Obtaining a Social Security Number (SSN)

International students who secure employment in the U.S. are eligible to apply for an SSN. Please visit BAEN Business Office to obtain initial information. Also, the ISSS provides detailed instructions on the application process, required documentation, and office locations. For comprehensive guidance, refer to the ISSS resources on [obtaining an SSN](#).

3. Acquiring a Texas Driver's License or State ID

Having a Texas driver's license or state ID is beneficial for identification and transportation purposes. The Texas Department of Public Safety (DPS) outlines the application process, necessary documents, and testing requirements. Visit the [DPS website](#) for detailed information.

4. Opening a Bank Account

Establishing a local bank account is crucial for managing finances. Several banks operate near the Texas A&M campus, offering services tailored to students. When choosing a bank, consider factors such as account fees, ATM accessibility, and online banking options. It's advisable to visit bank branches in person to discuss account options and requirements.

5. Housing Options

- **On-Campus Housing:** The Department of Residence Life offers various on-campus housing options for graduate students. Living on campus provides convenience and a sense of community. Explore available accommodations and application procedures on the Residence Life website.

- **Off-Campus Housing:** For those preferring off-campus living, the Off-Campus Student Services provides resources to assist in finding suitable housing, understanding leases, and connecting with potential roommates. Their website offers a comprehensive guide to off-campus living.

6. Health Insurance and Services

All students are required to have health insurance coverage. The [University Health Services](#) provides information on the university-sponsored health insurance plan, waiver processes, and access to medical services on campus. Detailed information is available on their website.

7. Campus Transportation

Navigating the campus and surrounding areas is facilitated by various [transportation options](#):

- **Aggie Spirit Buses:** Texas A&M offers a free bus service for students, covering campus and select off-campus locations. Schedules and routes can be found on the Transportation Services website.
- **Parking Permits:** If you plan to drive, parking permits are required for on-campus parking. Information on permit types, fees, and application procedures is available on the Transportation Services website.

8. Academic Resources

- **University Libraries:** The [Texas A&M University Libraries](#) offer extensive resources, including research materials, study spaces, and academic support services. Explore their offerings on the library website.
- **Graduate and Professional School:** This office provides support for graduate students, including information on degree requirements, funding opportunities, and professional development. Visit their website for more details.

9. Student Organizations and Involvement

Engaging in student organizations enhances your university experience:

- **Graduate and Professional Student Government (GPSG):** Represents the interests of graduate students and offers opportunities for involvement. Learn more on the GPSG website.
- **International Student Organizations:** Various cultural and interest-based organizations are available for international students. A list of recognized student organizations can be found on the Student Activities website.

10. Additional Support Services

- **Counseling and Mental Health Care Services:** Offers mental health support, counseling, and workshops to promote student well-being. Details are available on the CAPS website.

- [Career Center](#): Provides career counseling, resume workshops, and job search resources to assist in professional development. Visit the Career Center website for more information. If you are looking for part-time jobs, visit the [Jobs for Aggies](#) site.

We encourage you to utilize these resources to make the most of your time at Texas A&M University. Welcome to the Aggie family!